

Product Description

The C220_B Power Component is a customizable, high-output-current (HC) PWM Synchronous Buck, Voltage Mode Switching Regulator. Combine the C220_B component with other Power Components to create a custom-defined, AnDAPT AmP on-demand power management integrated circuit (PMIC).

Features

- PWM, voltage mode, point-of-load (POL) regulator
- Maximum output current: 10A
- PV_{IN} : 3 to 14V, V_{OUT} : 0.6V to 5.5V
- Adjustable output voltage with down to 2.4 mV resolution
- Integrated MOSFETs, $R_{DS(on)}$: 15m Ω (2 in parallel)
- 1% load regulation
- Efficiency up to 95%
- Internal compensator minimizes external part count
- Adjustable switching frequency from 300 kHz to 1.1 MHz
- Adaptable compensation, bandwidth, gain & phase margin
- Adjustable protection: Input Undervoltage Lockout, (ViUVLO), Output Undervoltage Lockout, (VoUVLO), Overcurrent (OCP), Overvoltage (OVP)
- Over Temperature Protection (OTP) (part of platform)
- Short-circuit protection (SCP)
- Power-good flag output and Enable input
- Soft start/stop, sequencing, pre-bias startup
- -40°C to +125°C operating junction temperature
- Four SIM elements; integrate up to two C220_B Power Components in one AmP Platform

Figure 1: C220_B application schematic

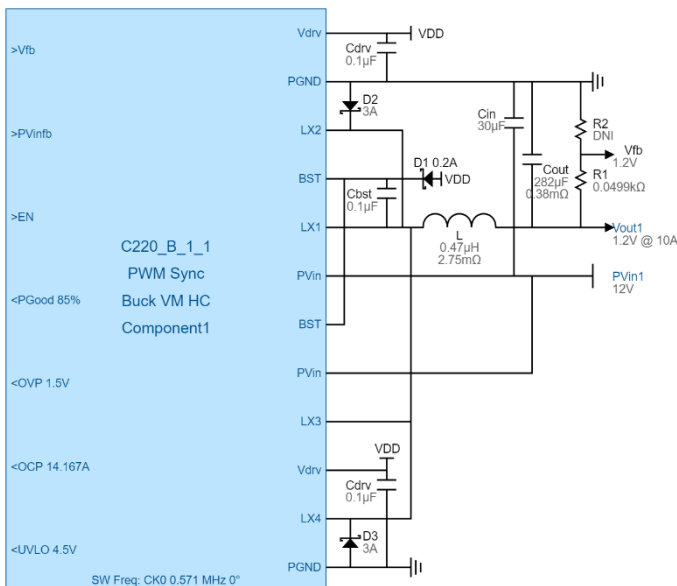

Applications

- On-demand power management, multi-rail power integration
- Powering server, processor, memory, storage, network switcher and router platforms
- FPGA, processor, SSD, subsystem power control & sequencing

Product Detail

The C220_B Synchronous Buck Regulator includes integrated MOSFETs, customizable PWM controller and various protection circuits.

The integrated, low-resistance switching Scalable Integrated MOSFETs (SIM) provide up to 10A output current. Output voltage feedback is compared against an internal reference using a high-performance, voltage-error digitizer that provides tight voltage regulation accuracy under transient conditions. Pulse-width modulated (PWM), voltage-mode regulation is implemented with PID compensation. The switching frequency is either generated internally via an oscillator with selectable frequencies or provided via an external pin.

The customizable output voltage is specified by the power engineer during customization using AnDAPT's cloud-based WebAmp development software. The C220_B component has customizable control and status pins including enable input, an optional power-good output, and optional output flags to signal when the system triggers an overvoltage (OVP), overcurrent (OCP), or input undervoltage lockout (ViUVLO) condition. The threshold values are specified by the power engineer using the WebAmp tool.

The customizable soft-start and soft-stop slew rates are also specified by the power engineer using the WebAmp tool. Additional sequencing options are available when used in conjunction with the C420 customizable Sequencer, by interconnecting signals EN and PGood to provide customizable dependencies and customizable delays between each sequence step.

Recommended Operating Conditions

over operating free-air temperature range

Symbol	Parameter	Min	Typ	Max	Unit
PV _{IN}	Power Input Voltage	3		14	V
I _{OUT}	I _{OUT} Output Current Maximum	10			A

Electrical Characteristics Buck Converters

PV_{IN}= V_{IN}=12V, T_A=25°C, C_{vdd}=10μF, C_{vcc}=1μF, unless otherwise specified

Parameters	Test Conditions	Min	Typ	Max	Units
Output Voltage (V _{OUT})		0.6		5.5	V
Voltage Regulation	Including load line and temperature variation V _{IN} range: 4.5V to 14V	-1		+1	%
Switching frequency (F _{SW})		300		1143	kHz
Switching frequency accuracy		-5		+5	%
MOSFET switch on-resistance (R _{DS(on)}) (two SIMs in parallel)			15		mΩ
Peak efficiency	V _{IN} =5V, V _{OUT} =3.3V, F _{SW} =571kHz I _{OUT} =3A		95		%
Efficiency	V _{IN} =12V, V _{OUT} =1.8V, F _{SW} =571kHz, I _{OUT} =4A		88		%
Input Shutdown current (V _{IN})	EN = 0V		13		mA
Input quiescent current (PV _{IN})			7		mA
PROTECTION					
ViUVLO, input Undervoltage Lockout		4		10	V
OCP, Over Current Protection (% I _{OUT})			142		%
OTP, Over Temperature Protection	Shutdown (Power Good goes low) Hysteresis	125			°C
OVP, Overvoltage Protection trip point range (relative to Parameter Setting)		+100		+432	mV
VoUVLO, output Undervoltage Lockout threshold range (relative to Parameter Setting)		-100		-432	mV
Power Good threshold (relative to Parameter Setting)		-100		-432	mV

* Parameters shaded in green are user customizable as set in WebAmP development software