

## Features

- Integrated PWM, current mode, point-of-load (POL) regulator
- Selectable number of phases: 2, 3, or 4
- Integrated, high-current solution up to 24A (four phases)
- Maximum output current per phase: Defined by selected device, 1A=AmP8D1, 3A=AmP8D3, 6A=AmP8D6
- $V_{in}$ : 3.0 to 13.2 V,  $V_{out}$ : 0.6V to 5.5V
- Adjustable output voltage with down to 1.2 mV resolution
- Automatic phase shedding, spreading
- Automatic current balancing
- Load current measurement
- Reduced output ripple currents
- Integrated MOSFETs,  $R_{DS(on)}$ : 40m $\Omega$
- 1% typical line and load regulation
- Efficiency up to 95%
- Internal single pole compensator minimizes external part count
- Analog slope compensation
- Adjustable switching frequency
- Additional capabilities – see I510, P510
- Adaptable stability, bandwidth, gain & phase margin
- Frequency synchronization: adjustable up to 2000 kHz
- Adjustable protection: Under-Voltage Lockout, (UVLO), Overcurrent (OCP), Overvoltage (OVP), and Over Temperature (OTP)
- Short-circuit protection (SCP)
- Power-good flag output and Enable input
- Soft start/stop, sequencing, pre-bias startup
- 52-, 58-, or 74-pin VQFN package
- -40°C to +125°C operating junction temperature
- Two SIM elements per phase

## Applications

- On-demand power management, multi-rail power integration
- Powering server, processor, memory, storage, network switcher and router platforms
- FPGA, processor, SSD, subsystem power control & sequencing

## Typical Application Circuit

Figure 1 provides a typical schematic for the C510 Power Component when integrated with other power rails in an AmP application.

### Power Component: C510S, C510P

Figure 1: C510 application schematic (two phases shown)

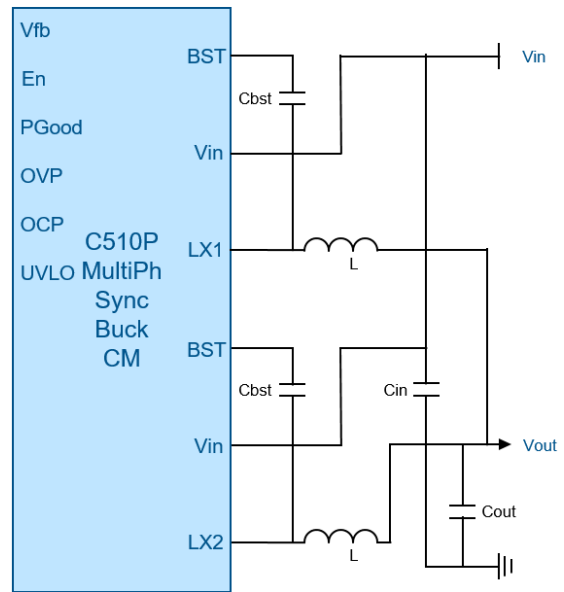

## Description

The C510 Power Component is a customizable PWM Multiphase Synchronous Buck, Current Mode Switching Regulator. Combine the C510 component with other Power Components to create a custom-defined, AnDAPT AmP on-demand power management device.

The integrated, low-resistance switching Scalable Integrated MOSFETs (SIMs) provide up to 6A output current. The maximum current for the C510 Power Component is defined by the number of phases (2, 3, or 4) and the maximum current of the selected AmP device.

Output voltage feedback is compared against an internal reference using a high-performance, voltage-error amplifier that provides tight voltage regulation accuracy under transient conditions. Pulse-width modulated (PWM), current-mode regulation is implemented with PID and slope compensation. The switching frequency is either generated internally via an oscillator with selectable frequencies or provided via an external pin. The C510 component has a customizable current switchover point between pulse-width modulation (PWM) for higher-current loads and pulse-skipping modulation (PSM) for low-current loads.

The customizable output voltage is specified by the power engineer during customization using AnDAPT's cloud-based WebAmP development software. The C510 component has customizable control and status pins including an optional enable input, an optional power-good output, and optional output flags to signal when the system triggers an overvoltage (OVP), overcurrent (OCP), or undervoltage lockout (UVLO) condition. The threshold values are specified by the power engineer using the WebAmP tool. The customizable soft-start and soft-stop slew rates plus ramp timing are also specified by the power engineer using the WebAmP tool.

## Customizable Options

[Table 1](#) lists the various customizable options available for the C510 Power Component. These options are set graphically in the WebAmp development software.

Table 1: C510 Customizable Options

Option	Units
Switching frequency	kHz
Input voltage	V
Output voltage	V
Ripple, % of output voltage*	%
Ripple, % of maximum output current*	%
Number of output phases	phases
Use optional En input to enable supply	On/Off
Use optional UVLO output to signal that output voltage is in under-voltage lockout condition	On/Off
Input voltage threshold for under-voltage lockout	V
Use optional OVP output to signal when over-voltage protection is triggered	On/Off
Over-voltage protection threshold	V
Use optional OCP output to signal when over-current protection is triggered	On/Off
Over-current protection threshold	A
Delay after enable to soft start	ms
Soft start rise time after enable	ms
Soft stop delay after disable	ms
Soft stop fall time after initial delay after disable	ms
Use optional PGood output to signal “power good”	On/Off
“Power good” threshold, percentage of output	%
Delay from “power good” until PGood asserted	ms
PID regulation coefficients ( $K_P$ , $K_I$ , $K_D$ )	
Threshold to switch between pulse-skipping mode (PSM) and pulse-width modulation (PWM)	A

\* to generate passive component recommendations

## Package Options

[Table 2](#) lists the package options available for the C510 Power Component. Typically, multiple AnDAPT power components are integrated into a single package.

Table 2: Package Options for C510

Pins	Dimension	SIM Bonding	Part Number
52	6 x 6 mm	Paired	C510P
58	7 x 7 mm	Paired	C510P
74	8 x 8 mm	Single	C510S

## Advanced Capabilities and Options

[Table 3](#) lists derivatives of the C510 component with additional capabilities plus other similar components potentially suitable for this application.

Table 3: C510 Advanced Capabilities Options

Description	Part Number
Standard Pro Series version (this component)	C510
Add external control via I <sup>2</sup> C bus interface	I510
Add telemetry and dynamic voltage scaling via DVS interface	P510
Single-phase buck regulator, synchronous, PWM, voltage mode regulation	C200
Single-phase buck regulator, asynchronous, PWM, voltage mode regulation	C250

## System Characteristics

[Table 4](#) lists the system characteristics for the C510 Power Component when implemented in an AnDAPT AmP device.

Table 4: C510 System Characteristics

Parameters	Min	Typ	Max	Units
<b>Power</b>				
Bias Supply Voltage ( $V_{BIAS}$ )	6		13.2	V
Input Drain Voltage ( $V_{IN}$ )	3		13.2	V
Output Voltage ( $V_{OUT}$ )	0.6		5.5	V
Output Current ( $I_{OUT}$ ) (per phase)	D6		6	A
	D3		3	
	D1		1	
Switching frequency ( $F_{SW}$ )			2000	kHz
Output MOSFET switch ( $R_{DS(on)}$ )		40		m $\Omega$
Load regulation ( $\Delta V_{OUT}/\Delta I_{OUT}$ )		1		%/A
Line regulation ( $\Delta V_{OUT}/\Delta V_{IN}$ )		1		%/V
Peak efficiency ( $V_{IN}=5V$ , $V_{OUT}=3.3V$ , $F_{SW}=500kHz$ )		95		%
<b>Control</b>				
Time to load change		5		$\mu$ s
Over-/under-shoot		$\pm 5$		%
Dynamic MOSFET current per segment		0.37		A
Soft start/stop delay	2		10	ms
Current Limit – OCP	0.2		6	A
Overvoltage protection trip point range (OVP)	0		5.5	V
Undervoltage lockout start threshold range (UVLO)	0		5.5	V

For other device specifications, see the AnDAPT AmP Platform datasheet.

## Additional Resources

- AnDAPT AmP Platform datasheet