

Features

- PWM, voltage mode, point-of-load (POL) regulator
- Maximum output current: Defined by selected device
1A=AmP8Dx1, 3A=AmP8Dx3, 6A=AmP8Dx6
- V_{IN} : 3.0 to 20 V, V_{OUT} : 0.6 V to 20 V
- Adjustable voltage response down to 1.2 mV resolution
- Integrated MOSFETs, $R_{DS(on)}$: 40m Ω
- 2% typical voltage regulation
- Efficiency up to 95%
- Internal single pole compensator minimizes external part count
- Adjustable switching frequency
- Additional capabilities – see I550, P550
- Adaptable stability, bandwidth, gain & phase margin
- Switching frequency: adjustable up to 1000 kHz
- Adjustable protection: Undervoltage Lockout, (UVLO), Overcurrent (OCP), Overvoltage (OVP)
- Short-circuit protection (SCP)
- Power-good flag output and Enable input
- Soft start/stop, sequencing, pre-bias startup
- 52-, 58-, or 74-pin VQFN packages
- -40°C to $+125^{\circ}\text{C}$ operating junction temperature
- Four SIM elements; integrate up to two C550 Power Components in one AmP platform

Typical Application Circuit

Figure 1 provides a typical schematic for the C550 Power Component when integrated with other power rails in an AmP application.

Figure 1: C550 application schematic

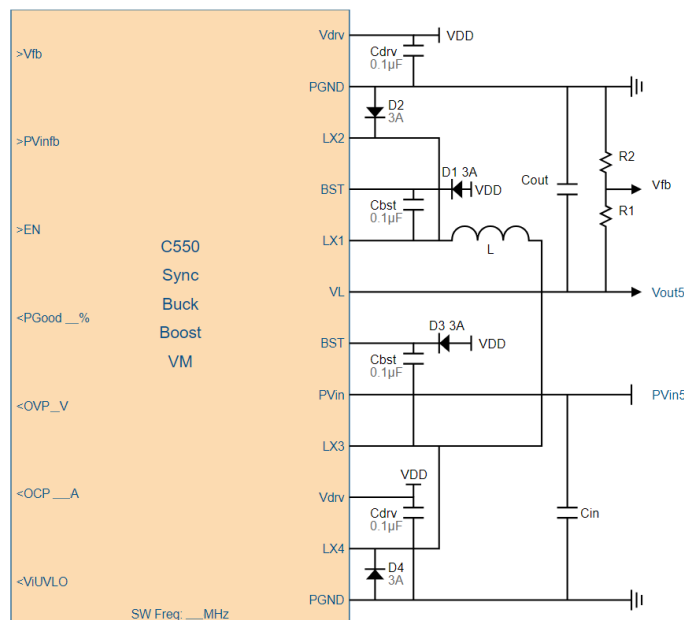

Applications

- On-demand power management, multi-rail power integration
- Powering server, processor, memory, storage, network switcher and router platforms
- FPGA, processor, SSD, subsystem power control & sequencing

Description

The C550 Power Component is a customizable, high-output-current PWM Synchronous Buck-Boost, Voltage Mode Switching Regulator. Combine the C550 component with other Power Components to create a custom-defined, AnDAPT AmP on-demand power management device.

The integrated, low-resistance switching Scalable Integrated MOSFETs (SIM) provide up to 6A output current. The maximum current is defined by the AmP device selected.

Output voltage feedback is compared against an internal reference using a high-performance, voltage-error amplifier that provides tight voltage regulation accuracy under transient conditions. Pulse-width modulated (PWM), voltage-mode regulation is implemented with PID compensation. The switching frequency is either generated internally via an oscillator with selectable frequencies or provided via an external pin. The C550 component has a customizable current switchover point between pulse-width modulation (PWM) for higher-current loads.

The customizable output voltage is specified by the power engineer during customization using AnDAPT's cloud-based WebAmp development software. The C550 component has customizable control and status pins including an optional enable input, an optional power-good output, and optional output flags to signal when the system triggers an overvoltage (OVP), overcurrent (OCP), or undervoltage lockout (UVLO) condition. The threshold values are specified by the power engineer using the WebAmp tool.

The customizable soft-start and soft-stop slew rates plus ramp timing are also specified by the power engineer using the WebAmp tool. Additional sequencing options are available when used in conjunction with the C410 customizable Sequencer, by interconnecting signals EN, PGood, OVP, OCP, UVLO, to provide customizable dependencies and customizable delays between each sequence step, ranging 0.25 to 4 ms.

Customizable Options

[Table 1](#) lists the various customizable options available for the C550 Power Component. These options are set graphically in the WebAmp development software.

Table 1: C550 Customizable Options

Option	Units
Switching frequency	MHz
Input voltage	V
Output voltage	V
Ripple, % of output voltage*	%
Overshoot, output voltage*	V
Output Current	A
Ripple, % of maximum output current*	%
Output Current Delta*	A
LC Component Manual/Auto select	On/Off
Inductor	μH
Inductor DCR	mΩ
Capacitor	μF
Capacitor ESR	mΩ
PID regulation coefficients (K_P , K_I , K_D)	
Enable OCP output to signal when overcurrent protection is triggered	On/Off
Overcurrent protection level	A
Enable OVP output to signal when overvoltage protection is triggered	On/Off
Overvoltage protection level	V
Enable input UVLO to signal when undervoltage lockout protection is triggered	On/Off
Undervoltage lockout sense level	V
UVLO sense	Ext/Int
Enable soft start	On/Off
Output UVLO voltage	V
Soft start rise time after enable	ms
Use optional PGood output to signal "power good"	On/Off
"Power good" threshold, percentage of output	%

* to generate passive component recommendations

Package Options

[Table 2](#) lists the package options available for the C550 Power Component. Typically, multiple AnDAPT power components are integrated into a single package.

Table 2: Package Options for C550

Pins	Dimension	SIM Bonding	Package
52	6 x 6 mm	Paired	QN52
58	7 x 7 mm	Paired	QN58
74	8 x 8 mm	Single	QF74

Advanced Capabilities and Options

[Table 3](#) lists derivatives of the C550 component with additional capabilities plus other similar components potentially suitable for this application.

Table 3: C550 Advanced Capabilities Options

Description	Part Number
Standard Pro Series version (this component)	C550
Add external control via I ² C bus interface	I550
Add telemetry and dynamic voltage scaling via DVS interface	P550
Single-phase buck regulator, synchronous, PWM, voltage mode regulation	C200
Single-phase buck regulator, asynchronous, PWM, voltage mode regulation	C250
Single-phase boost regulator, synchronous, PWM, voltage mode regulation	C350

System Characteristics

[Table 4](#) lists the system characteristics for the C550 Power Component when implemented in an AnDAPT AmP device.

Table 4: C550 System Characteristics

Parameters	Min	Typ	Ma	Units
Power				
Bias Supply Voltage (V_{BIAS})	3		20	V
Input Drain Voltage (PV_{IN})	3		20	V
Output Voltage (V_{OUT})	0.6		20	V
Output Current (I_{OUT})	Dx6		6	A
	Dx3		3	
	Dx1		1	
Switching frequency (F_{SW})			1	MHz
Output MOSFET switch ($R_{DS(on)}$)		40		mΩ
Voltage regulation		1		%/V
Peak efficiency ($V_{IN}=5V$, $V_{OUT}=3.3V$, $F_{SW}=500kHz$)		95		%
Control				
Over/undershoot		±5		%
Dynamic MOSFET current per segment		0.37		A
Current Limit – OCP	0.2		6	A
Overvoltage protection trip point range (OVP)		$V_{OUT} + 1$		V
Undervoltage lockout start threshold range (UVLO)		$V_{OUT} / 1.2$		V

For other device specifications, see the AnDAPT AmP Platform datasheet.

Additional Resources

- AnDAPT AmP Platform datasheet