

## Product Description

The I470 Component is a customizable 2 channel source selector targeted at DC power with battery backup or dual battery applications.

## Features

- Two independent window comparators
- Parameterized UVLO and OVP thresholds
- Parameterized rising/falling hysteresis on thresholds
- Independent “OK” outputs
- “EN”able outputs with priority encoding of A Over B
- I2C readable status register
- I2C adjustable UVLO thresholds

## Applications

- Dual Power Sources
- Dual battery source selection
- DC / Battery pack backup source selection

Figure 1: I470 component

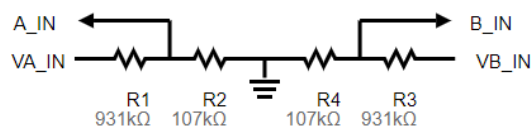
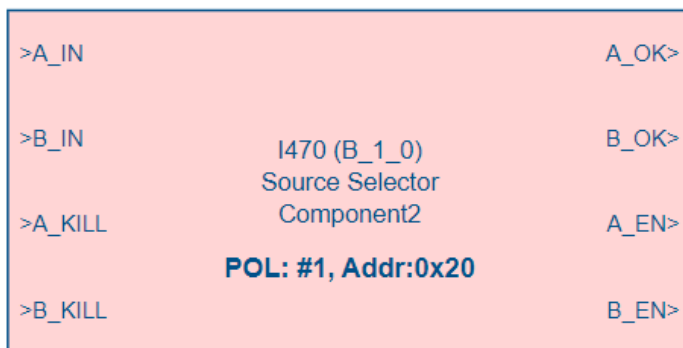

## Product Detail

The I470 Source Selector enables priority selection of two external high voltage sources based on programmable UVLO and OVP threshold parameter settings. Thresholds are set in WebAMP parameter settings and can be updated over I2C. The following describes the Source Selector operation.

## Operations

- Independent UVLO thresholds are available for A\_IN and B\_IN
- UVLO falling thresholds are parameters and can also be modified via I2C
- UVLO Hyst is a parameter
- UVLO rising thresholds are generated from UVLO falling + UVLO Hyst
- Both inputs use same OVP rising and OVP falling threshold parameters
- An input is OK if it sits between its UVLO and OVP thresholds
- Selection Logic will prioritize A\_ENABLE over B\_ENABLE
- Both sources can be disabled using the A\_KILL and B\_KILL inputs

Pin Function and Description Table

Port Name	I/O	Description
A_IN	I	source A input voltage
B_IN	I	source B input voltage
A_KILL	I	Source A kill input. Causes A_EN to be de-asserted. If B is OK, B_EN will be asserted
B_KILL	I	Source B kill input. Causes B_EN to be de-asserted
A_OK	O	Indicator that A_IN is between its UVLO and OVP thresholds
B_OK	O	Indicator that B_IN is between its UVLO and OVP thresholds
A_EN	O	Signal to enable Source A
B_EN	O	Signal to enable Source B

Figure 2: I470 Block Diagram

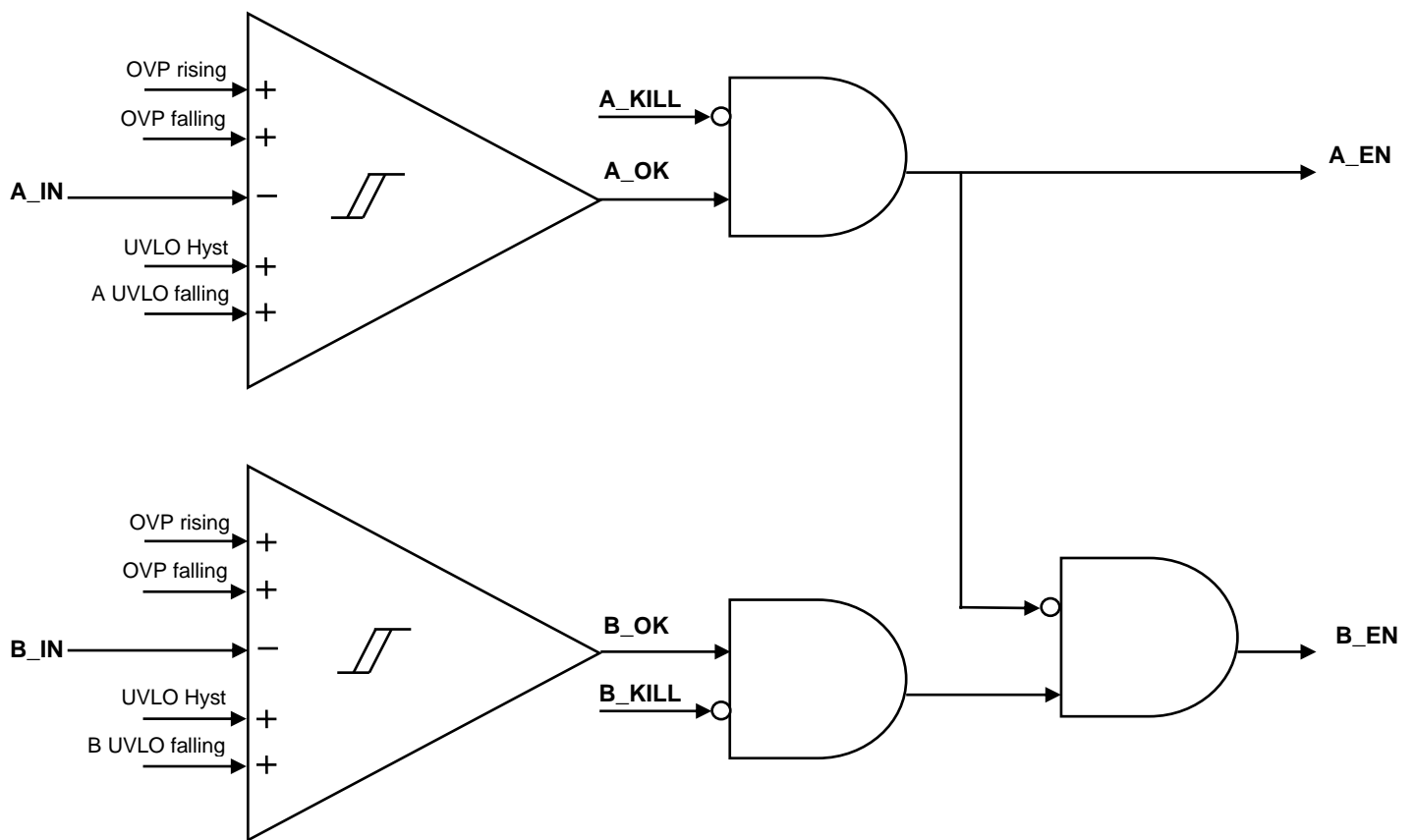

Fig.1 I470 Logic diagram

