

Features

- AmP8DB6QF65 platform 5x5 mm² package on board
- Demonstrates Power Components:
 - Synchronous Buck
 - Asynchronous Buck
 - LDO
 - Load Switch
 - Supervisor Functions
- Connects to USB adapter (no AmPLink™ required)
- WebAmP Tool Downloads Configuration File
 - .HEX file (Intel HEX) to program on board Flash
 - .HAX file to configure AmP device directly

Description

The AmP8DB2 Rev 2.0 is a ready to use Demonstration Board to evaluate Power Components on the AmP, Adaptive Multi-Rail Power Platform. Simply drag and drop Power Components in the WebAmP design tool and compile into a Configuration Bitstream File. In the AmPLink Control tab, download the file over the USB adapter to the AmP8DB2 Rev 2.0 Demonstration Board. The .HEX file is used to download to the Flash memory or the .HAX file is used to download directly to the AmP Platform. Synchronous Buck, Async Buck, LDO, Load Switch and Supervisor Power Components may then be evaluated.

Application of Demonstration Board

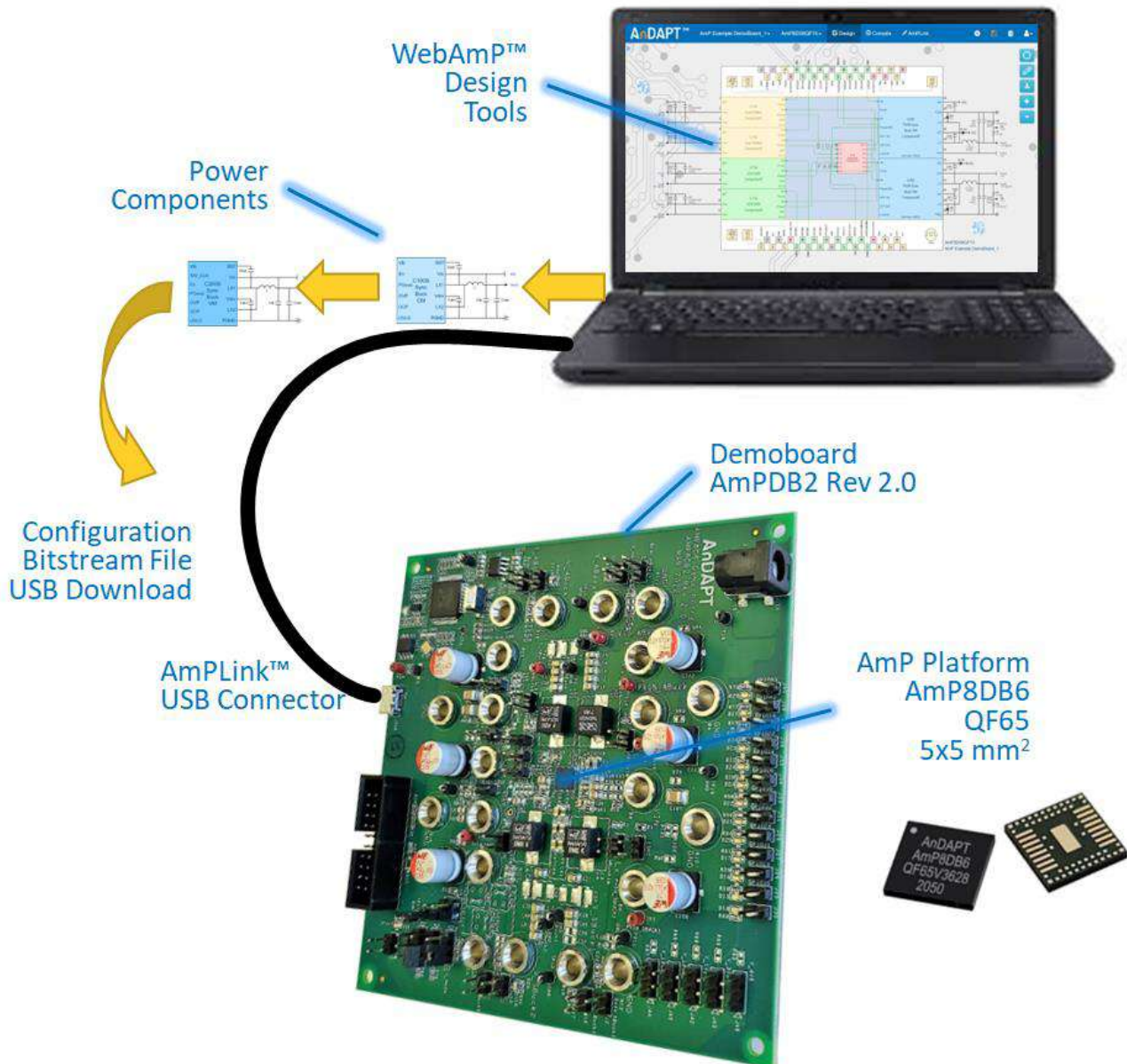

Getting Started

Step 1.

Set jumper connections to the default configuration

Load AmP from USB as shown in the Jumper Selection Table. Also provided for clarity is a jumper legend on the PCB silkscreen. For details see: [AmPLink Config & Cntrl](#)

Step 2.









Connect power supplies to Vin, Sync Buck1 PVin and GND banana jacks as shown in the figure below. In this example, use Vin = PVIN = 12V.

Step 3.

Download [AmP8DB2_B_syncBuck2x_LDO1x.json](#) project file, Import to WebAmP and compile. Connect AmPLink USB cable to computer and to J348 as shown on page 1. From the AmPLink tab, install AmPLink drivers if required, then click Program & Verify. Set CTRL, EN, to "1". Observe 1.2V on the Vout banana plug below.

See: [Video - Using AmPLink](#)

Jumper Selection Table for J20 and J29

Function	Header	Load AmP from FLASH	Load AmP from USB	Program FLASH from USB
Chip Select	J20 	1-2 	2-4 	1-3 
Mode	J29 	1-2 	2-3 	2-3 

Power Supply and Jumper Configurations

Connect power supplies here  Monitor voltage out here 

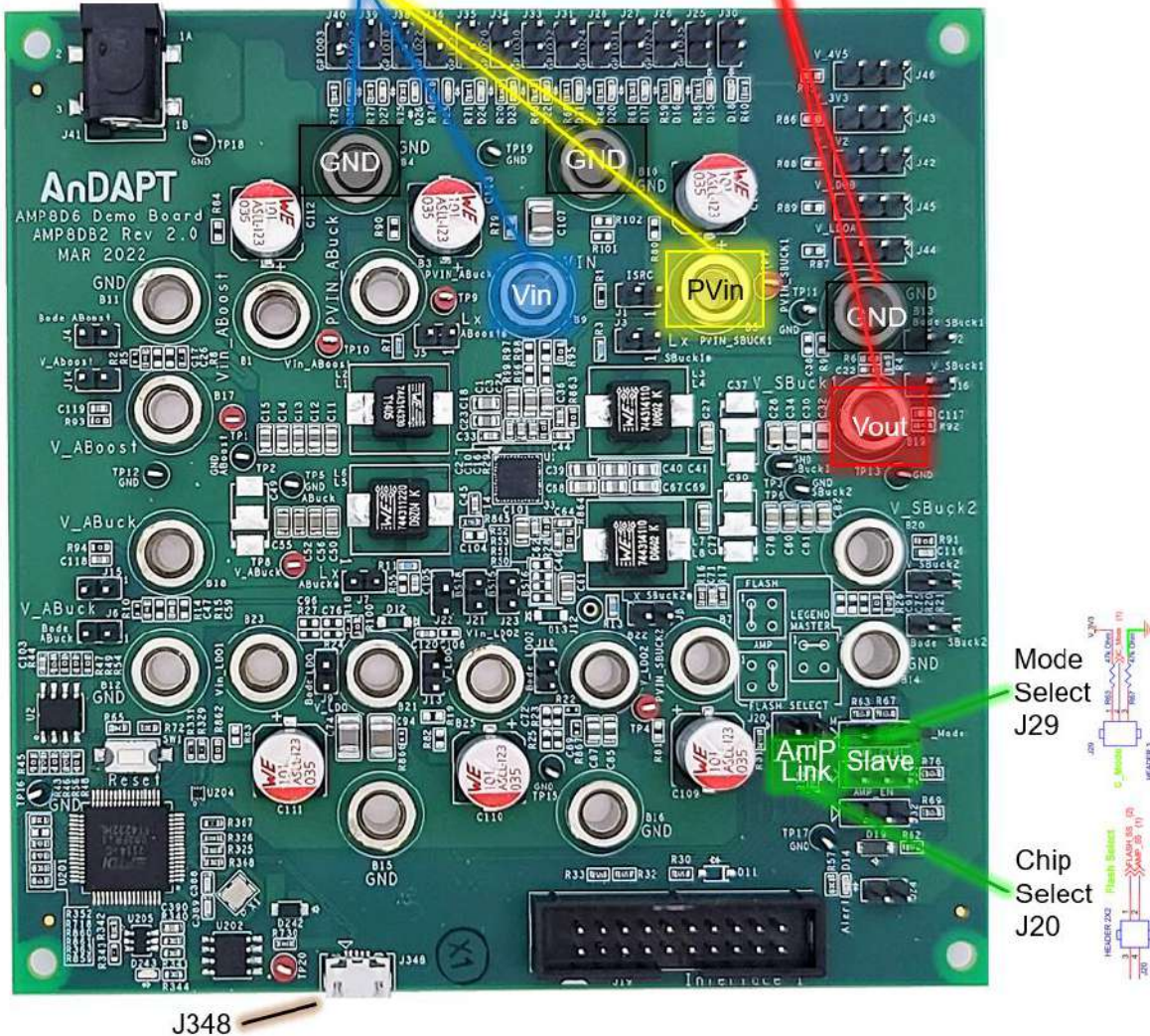

Measuring Board Performance

There are various performance measurements that are typically made on an evaluation board. Many of these measurements require careful measurements with key test points that are often different for various measurements. For example the best place to sense V_{out} for ripple or transient is different from the point used to measure efficiency. The next few sections will go over the recommended test points for the various measurements.

Efficiency Measurement Points

To measure efficiency on the AMP8DB2 Demo Board, care must be taken to sense the voltages appropriately. The Eval Board has included test points to measure efficiency for each of the switching regulators: the two 6 Amp Synchronous Buck regulators (SBuck1 and SBuck2), and the Non-Synchronous Buck (ABuck). The figure below shows the test points.

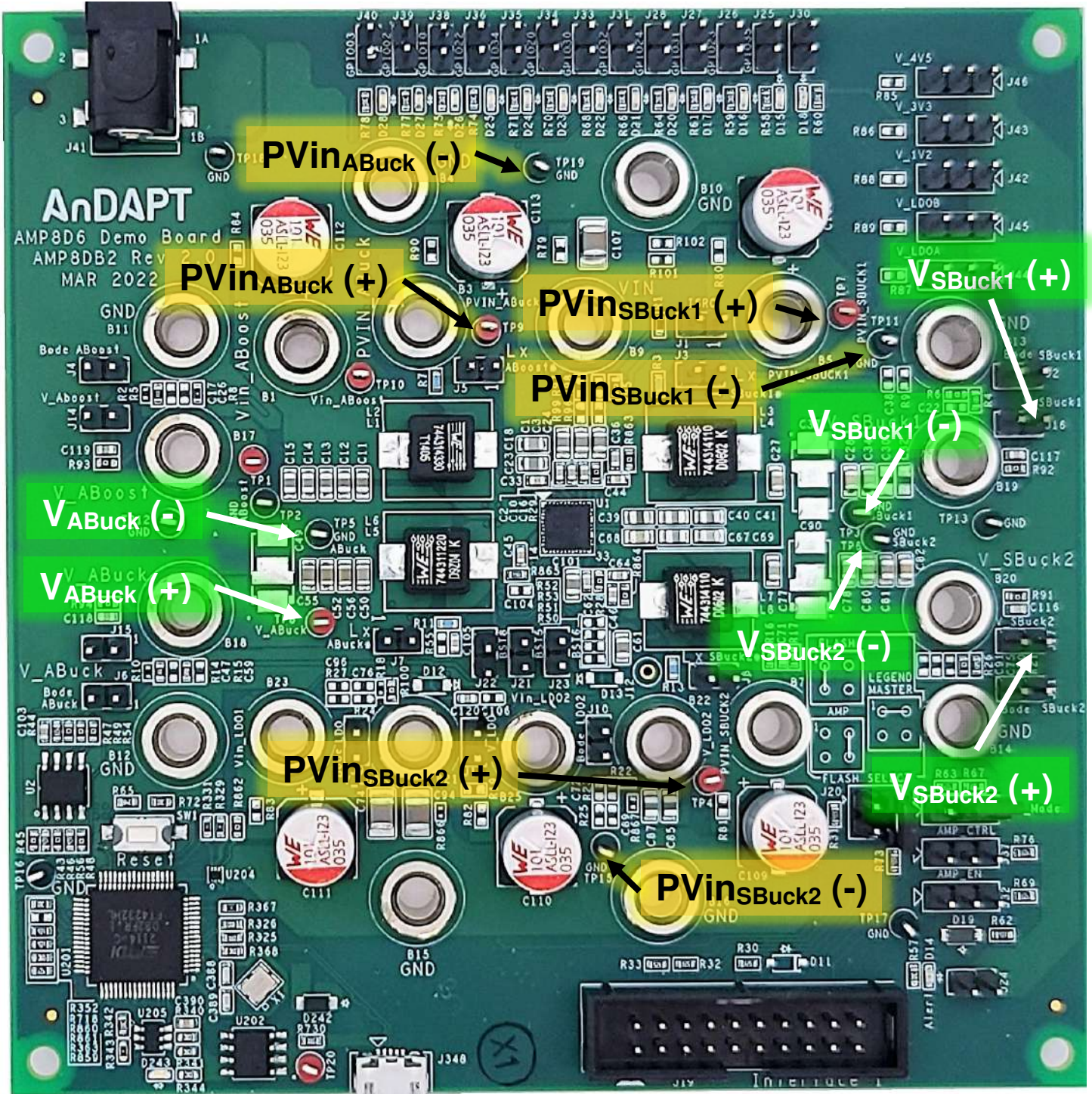

Ripple, Voltage Regulation, and Transient Response

To measure the output ripple and regulation voltages, several 2-pin 100-mil headers are provided on the board. These can be used to connect directly to an oscilloscope using a standard BNC to female header pin cables. The headers for each of the switching regulators are shown below.

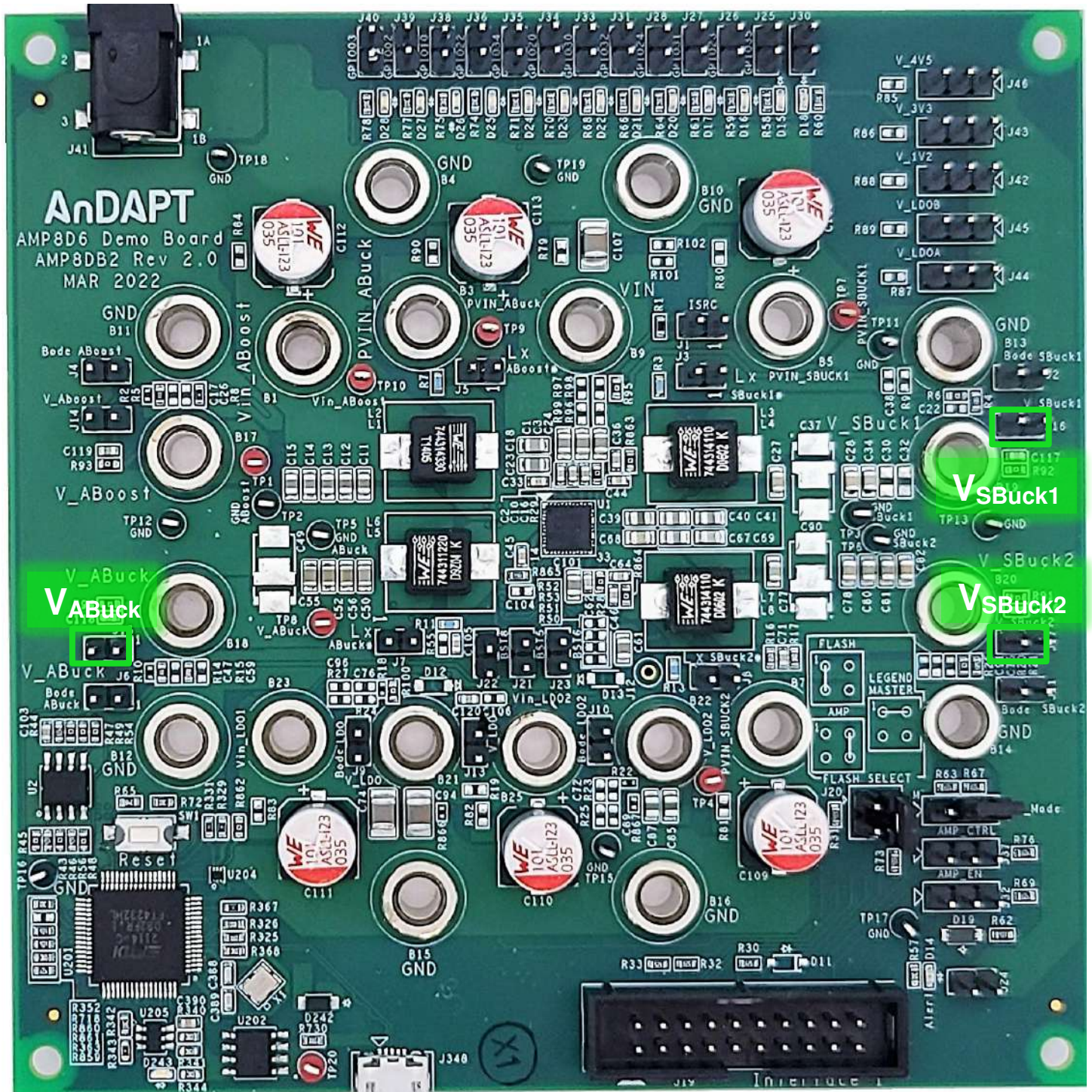

Getting Started with WebAmP example project, AmP Example B_syncBuck2x_LDO1x

Project File: [AmP8DB2_B_syncBuck2x_LDO1x.json](#)

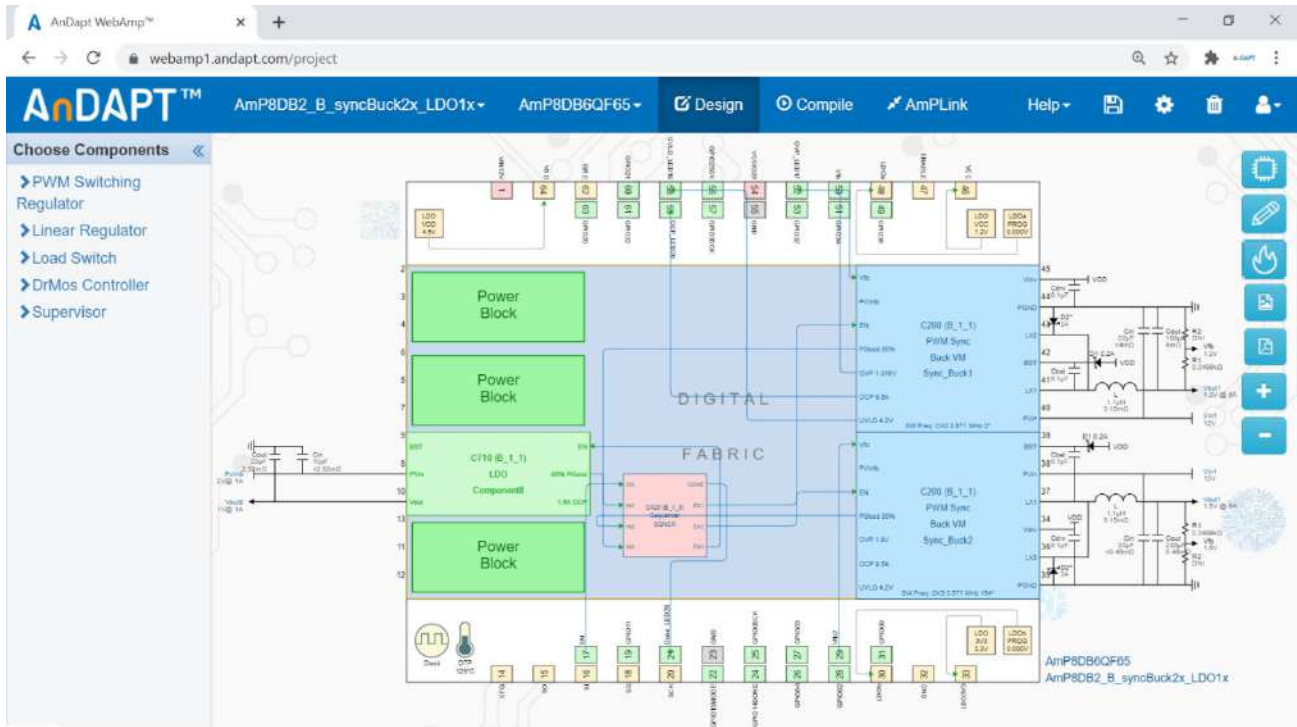

Getting Started with WebAmP: Install AmPLink

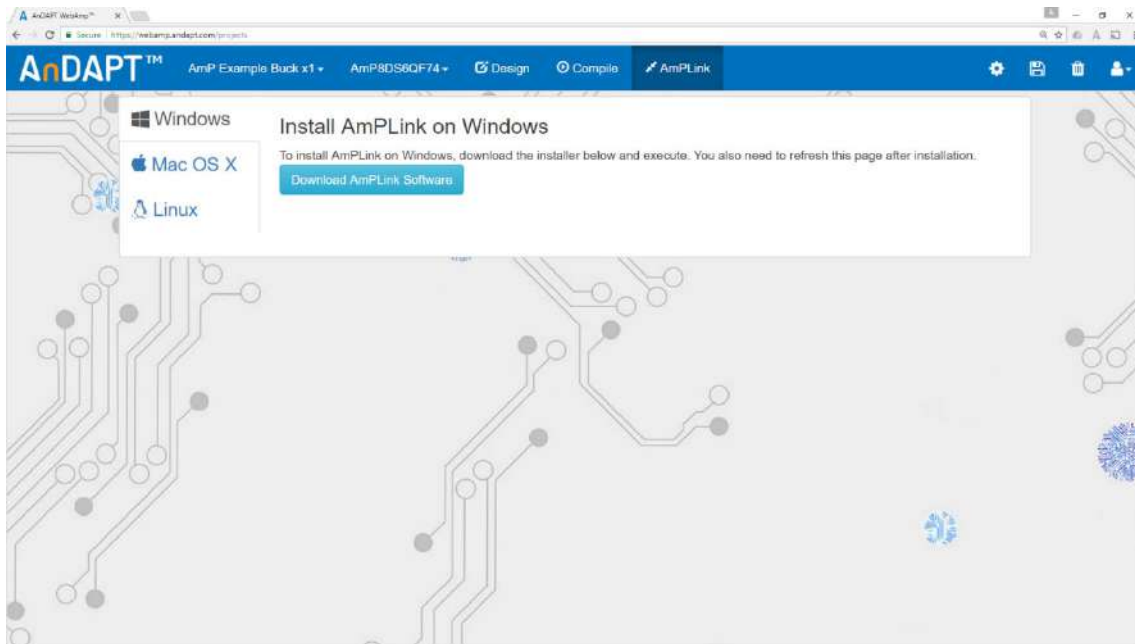

Getting Started with WebAmP: AmPLink Program, Verify & Status

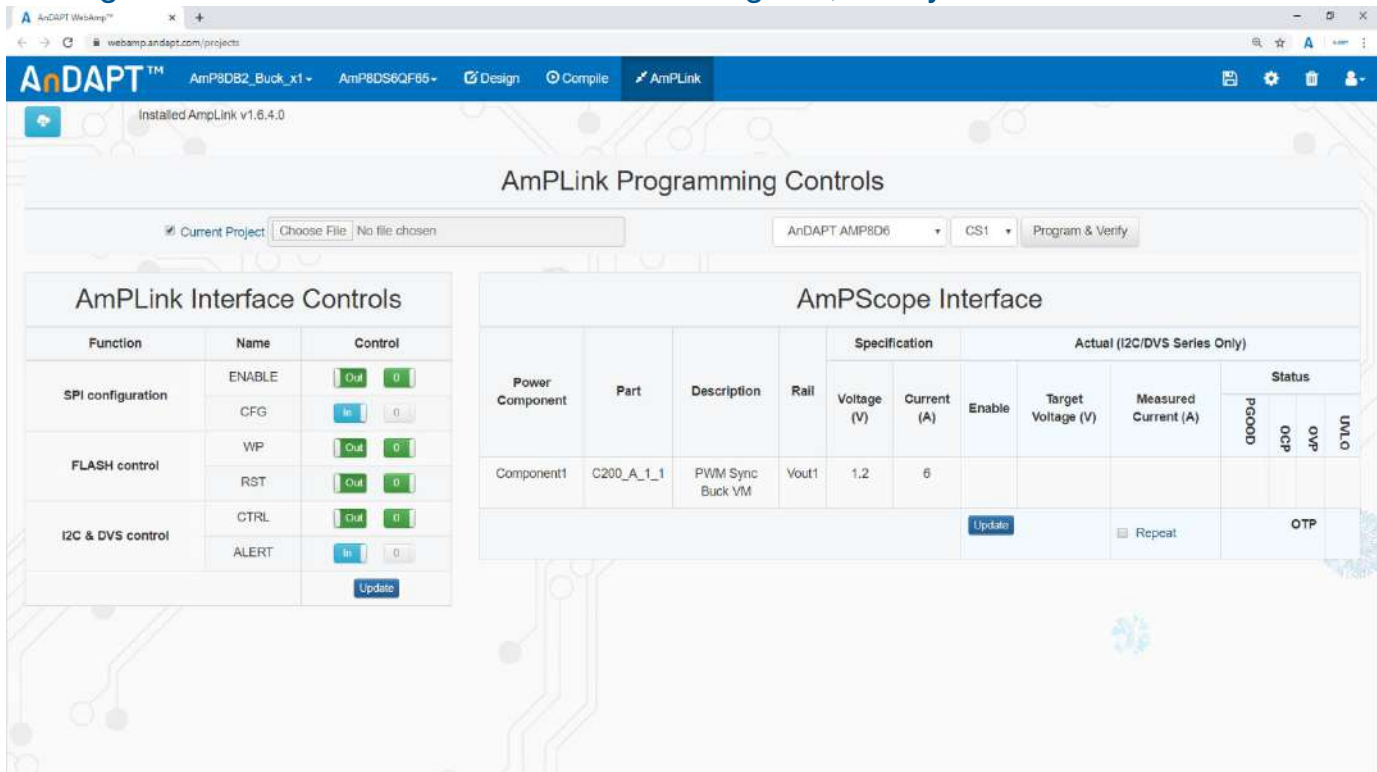

AmPLink Pin Out

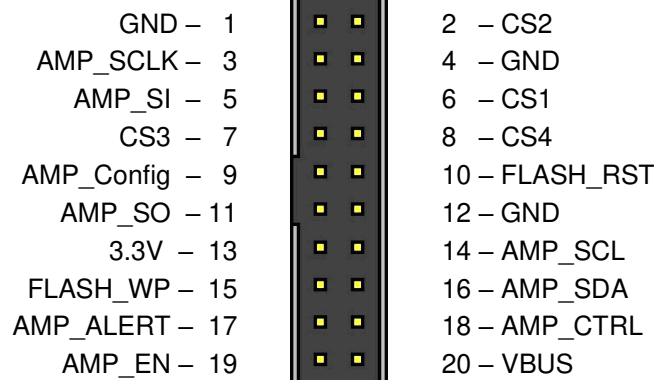

LDO Examples

LDO examples for testing a single LDO at a time.

Project File: [AmP8DB2 B LDO1 1x.json](#)

Project File: [AmP8DB2 B LDO2 1x.json](#)

Project File: [AmP8DB2 LED Blink 2Hz.json](#)

Project File: [AmP8DB2 LED Count 2Hz.json](#)

Project File: [AmP8DB2 LED Shift 2Hz.json](#)

Demonstration Board AmP8DB2 Schematic

See appendix at end of document for searchable schematic and PCB layout.

Basic LED Examples

Basic includes Blink, Count and Shift examples to demonstrate use of C430 AND gate, C430 NOR gate, C432 DFF4, and C450 Reset Generator

Bill of Materials

Item	Qty	Reference	Value	Description
1	21	B1,B3,B4,B5,B7,B9,B10,B11,B12,B13,B14,B15,B16,B17,B18,B19,B20,B21,B22,B23,B25	BANANA-4MM	CONN BANANA JACK SOLDER
2	13	C1,C3,C4,C18,C19,C20,C21,C23,C24,C60,C61,C100,C101	10 uF	CAP CER 10UF 16V X5R 0805
3	22	C2,C10,C16,C25,C33,C36,C44,C45,C46,C62,C64,C71,C97,C98,C102,C103,C105,C116,C117,C118,C119,C120	0.1 uF	CAP CER 0.1UF 50V X7R 0603
4	10	C5,C6,C7,C8,C9,C11,C12,C13,C14,C15	4.7 uF	CAP CER 4.7UF 16V X7R 0805
5	12	C17,C22,C26,C38,C47,C59,C72,C75,C76,C89,C91,C96	DNI	CAP CER 6800PF 50V X7R 0603
6	15	C27,C28,C29,C34,C35,C68,C69,C77,C78,C79,C80,C81,C82,C92,C93	47 uF	CAP CER 47UF 6.3V X7R 0805
7	3	C30,C31,C32	22 uF	CAP CER 22UF 35V X5R 0805
8	2	C37,C70	DNI-220 uF	CAP ALUM POLY 220UF 20% 2V SMD
9	9	C39,C40,C41,C42,C43,C83,C84,C85,C87	22 uF	CAP CER 22UF 10V X5R 0805
10	1	C48	22 uF	22uF 16V X5R +/-20% 1210
11	2	C49,C90	220 uF	CAP ALUM POLY 220UF 20% 2V SMD
12	4	C50,C52,C55,C56	47 uF	CAP CER 47UF 10V X5R 0805
13	5	C51,C53,C54,C57,C58	DNI	CAP CER 4.7UF 10% 16V X7R 0805
14	1	C63	10 uF	CAP CER 10UF 35V X5R 0805
15	3	C65,C66,C67	22 uF	CAP CER 22UF 35V X5R 0805
16	2	C74,C94	22 uF	CAP CER 22UF 25V X5R 1210
17	1	C88	DNI	CAP CER 22UF 10V X5R 0805
18	1	C95	DNI	CAP CER 22UF 25V X5R 1210
19	1	C99	0.01 uF	CAP CER 0.01uF 25V X7R 10% 0603
20	2	C104,C106	DNI_0.1 uF	CAP CER 0.1UF 50V X7R 0603
21	1	C107	10 uF	CAP CER 10UF 25V X7R 1210
22	6	C108,C109,C110,C111,C112,C113	100 uF	CAP ALUM 100UF 20% 35V SMD
23	4	C369,C371,C374,C382	10u	CAP CER 10UF 35V X5R 0603
24	16	C370,C372,C373,C375,C376,C377,C378,C379,C380,C381,C383,C384,C385,C386,C387,C390	100n	CAP CER 0.1UF 50V X7R 0603
25	2	C388,C389	18p	CAP CER 18PF 50V COG/NPO 0603
26	2	D1,D3	VSSC8L45-M3	DIODE SCHOTTKY 45V 4.9A DO214AB
27	2	D2,D4	RBR2MM40BTR	DIODE SCHOTTKY 40V 2A PMDU
28	3	D5,D6,D8	RB521S30T5G	DIODE SCHOTTKY 30V 200MA SOD523
29	1	D7	RB521S30T5G	DIODE SCHOTTKY 30V 200MA SOD523
30	1	D9	BAT54SLT1G	DIODE SCHOTTKY 30V 200mA SOT-23
31	1	D11	DNI-B140HW-7	DIODE SCHOTTKY 40V 1A SOD123

Bill of Materials

Item	Qty	Reference	Value	Description
32	2	D12,D13	DNI_5V6	Zener Diode 5.6V 400mW ±2% SOD-323
33	2	D14,D18	LED-ORANGE	LED RED CLEAR 0603 SMD
34	13	D15,D16,D17,D20,D21,D22,D23,D24,D25,D26,D27,D28,D243	LED-GREEN	LED GREEN CLEAR 0603 SMD
35	2	D19,D242	BAS116GWX	DIODE GEN PURP 75V 215MA SOD123
36	33	J1,J2,J3,J4,J5,J6,J7,J8,J9,J10,J11,J13,J14,J15,J16,J17,J21,J22,J23,J24,J25,J26,J27,J28,J30,J31,J33,J34,J35,J36,J38,J39,J40	HEADER 2	CONN HEADER 2 POS 2.54
37	1	J12	DNI	CONN HEADER 9 POS 2.54
38	1	J19	HEADER 10X2	CONN HEADER VERT 20POS GOLD
39	1	J20	HEADER 2X2	CONN HEADER VERT DUAL 4POS 2.54
40	8	J29,J32,J37,J42,J43,J44,J45,J46	HEADER 3	CONN HEADER 3 POS 2.54
41	1	J41	CONN JACK PWR	CONN PWR JACK 2.5X5.5MM SOLDER
42	1	J348	USB_CONN	CONN USB MICRO B RECPT SMT R/A
43	1	L1	DNI	Inductors 1UH 20% 100KHZ METAL 3.8A 36.9
44	1	L2	3.3 uH	FIXED IND 3.3UH 9A 9 MOHM SMD
45	2	L3,L7	1.1 uH	FIXED IND 1.1UH 15A 3.15MOHM SMD
46	3	L4,L6,L8	DNI	
47	1	L5	2.2 uH	FIXED IND 2.2UH 9A 11.4 MOHM SMD
48	1	R1	1 Ohm	RES SMD 1 OHM JUMPER 1/8W 0603
49	3	R2,R18,R22	49.9 Ohm	RES SMD 49.9 OHM 1% 1/16W 0402
50	4	R3,R7,R11,R13	953 Ohm	RES SMD 953 OHM 1% 1/8W 0603
51	2	R4,R21	49.9 Ohm	RES SMD 49.9 OHM 1% 1/10W 0603
52	1	R5	12.1k Ohm	RES SMD 12.1K OHM 1% 1/10W 0603
53	19	R6,R20,R28,R29,R38,R45,R46,R47,R48,R49,R54,R91,R92,R93,R94,R95,R100,R863,R864	0 Ohm	RES SMD 0 OHM JUMPER 1/10W 0603
54	1	R8	1K Ohm	RES 1K OHM 1% 1/10W 0603 SMD
55	19	R9,R25,R26,R27,R40,R41,R42,R51,R52,R55,R85,R86,R87,R88,R89,R96,R97,R98,R99	DNI	-
56	1	R10	49.9 Ohm	RES SMD 49.9 OHM 1% 1/16W 0402
57	1	R12	0 Ohm 20A	RES SMD 0 OHM JUMPER 1/2W 0603 200uohm

Bill of Materials

Item	Qty	Reference	Value	Description
58	1	R14	6.34k Ohm	RES SMD 6.34K OHM 1% 1/10W 0603
59	1	R15	1.43k Ohm	RES 1.43K OHM 1% 1/10W 0603
60	1	R16	750k Ohm	RES SMD 750K OH 1% 1/10W 0603
61	1	R17	249k Ohm	RES SMD 249K OH 1% 1/10W 0603
62	8	R19,R79,R80,R81,R82,R83,R84,R90	DNI	RES SMD 0 OHM JUMPER 1/2W 0603 200uohm
63	2	R23,R24	0 Ohm 20A	-
64	3	R30,R32,R33	34.0 Ohm	RES SMD 34 OHM 1% 1/10W 0603
65	10	R31,R43,R44,R56,R62,R63,R67,R69,R73,R76	47k Ohm	RES SMD 47K OHM 1% 1/10W 0603
66	1	R50	DNI_10k Ohm	RES SMD 10K OHM 1% 1/10W 0603
67	1	R53	DNI_330k Ohm	RES SMD 330K OH 1% 1/10W 0603
68	15	R57,R58,R59,R60,R61,R64,R66,R68,R70,R71,R72,R74,R75,R77,R78	10k Ohm	RES SMD 10K OHM 1% 1/10W 0603
69	1	R65	2.21k Ohm	RES SMD 2.21K OH 1% 1/10W 0603
70	2	R101,R102	DNI	RES SMD 47K OHM 1% 1/10W 0603
71	3	R325,R326,R730	10R	RES SMD 10 OHM 1% 1/10W 0603
72	5	R329,R330,R331,R343,R367	1k	RES 1K OHM 1% 1/10W 0603 SMD
73	10	R333,R334,R335,R340,R341,R342,R344,R352,R363,R368	10k	RES SMD 10K OHM 1% 1/10W 0603
74	3	R338,R339,R718	DNI	
75	2	R357,R862	0R	RES SMD 0 OHM JUMPER 1/10W 0603
76	1	R856	34R	RES SMD 34 OHM 1% 1/10W 0603
77	3	R859,R860,R861	470R	RES 470 OHM 1% 1/10W 0603
78	1	R865	15 Ohm	RES SMD 15 OHM 5% 1/10W 0603
79	2	R866,R867	3k Ohm	RES 3K OHM 1% 1/16W 0402
80	1	SW1	SW PUSHBUTTON	SWITCH TACTILE SPST-NO 0.05A 12V
81	6	TP1,TP4,TP7,TP8,TP9,TP10	TP_RED	TEST POINT PC MINI .040"D RED
82	12	TP2,TP3,TP5,TP6,TP11,TP12,TP13,TP15,TP16,TP17,TP18,TP19	TP_BLACK	TEST POINT PC MINI .040"D BLACK
83	1	TP20	TP_RED	TEST POINT PC MINI .040"D RED
84	1	U1	AMP8DQF65	-
85	1	U2	AT25DF512C	IC FLASH 512KBIT 85MHZ 8SOIC
86	1	U201	FT4232HL-Reel	IC USB HS QUAD UART/SYNC 64-LQFP
87	1	U202	MCP1725	
88	1	U203	TS3USB30ERS WR	IC USB SWITCH DUAL 1X2 10UQFN
89	1	U204	SN74LVC2G07	
90	1	U205	93LC46BT-I/OT	
91	1	X1	12MHz	CRYSTAL 12.0000MHZ 18PF SMD

Additional Resources

- [AmP Platform Datasheet](#)
- [AmPLink USB Adapter Datasheet](#)
- [AmPLink Configuration and Control](#)
- [Video - WebAmP Development Software](#)
- [Video - Using AmPLink](#)
- Power Components Datasheets

Revision History

Date	Revision
7/12/2022	Initial Rev 2.0



On-Demand Power Management

<https://www.andapt.com>

Trademarks

© 2022 AnDAPT, the AnDAPT logo, AmP, WebAmP, AmPLink, AmPScope and other designated brands included herein are trademarks of AnDAPT in the United States and other countries. All other trademarks are the property of their respective owners.

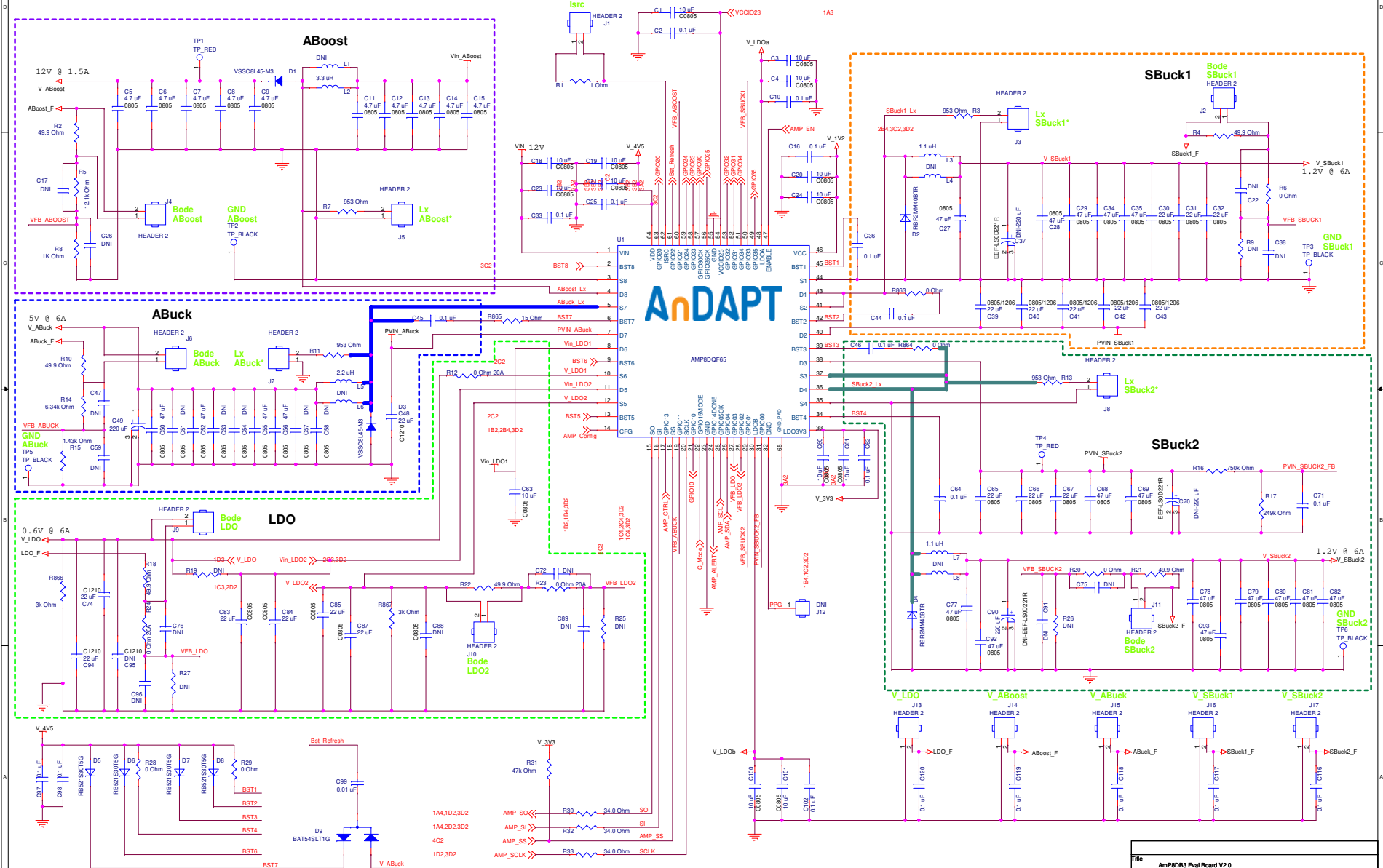
Notes:
 Two Inductors are shown in each switching rail. These indicate that the smallest physical size inductor is from 3mm square to 10mm square depending on application.
 All ports marked with an * indicate that these are designed to terminate into 50 ohms with a 20X attenuation across the 50 ohms.



File	AMP8083 Eval Board V2.0	Rev	1.0
Size	Document Number: AMP8083_REV2_SXS_ENG_01162022	Sheet	1 of 4
Date:	Friday, May 20, 2022		

Interface 1

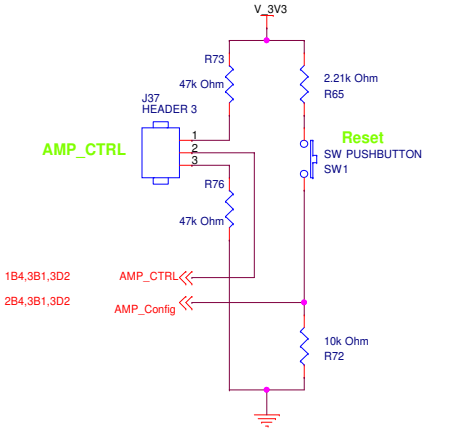
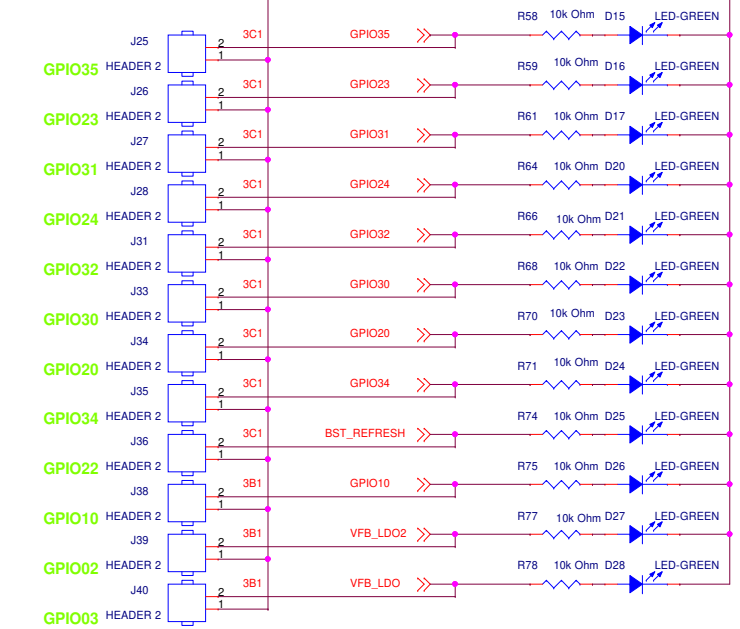
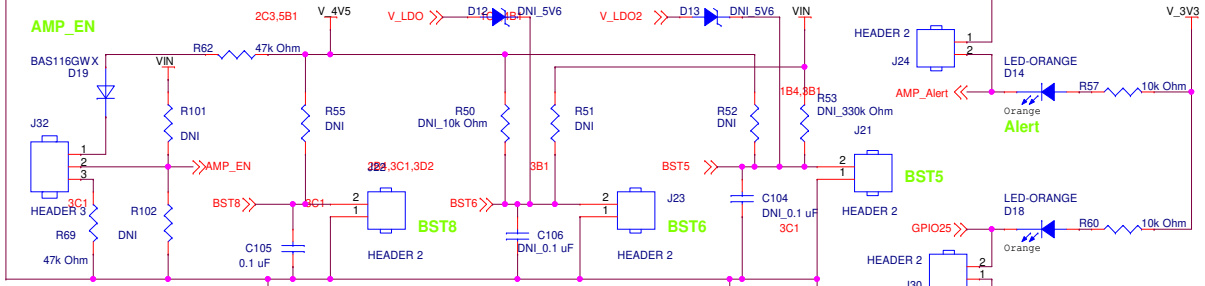
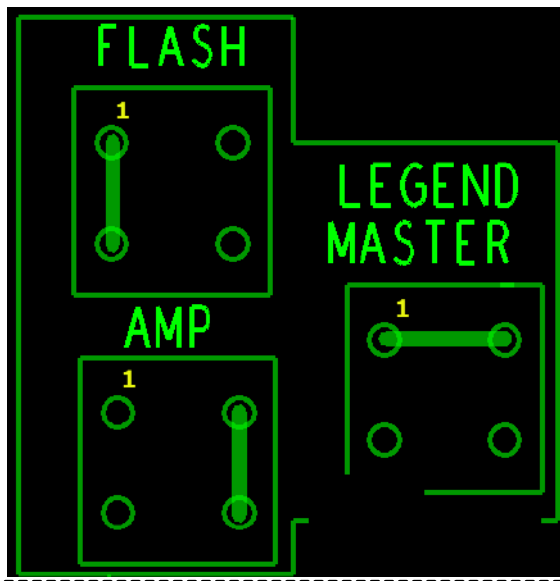
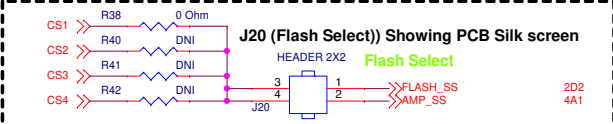
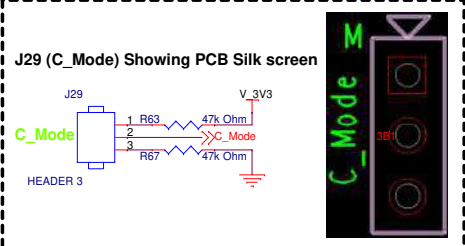
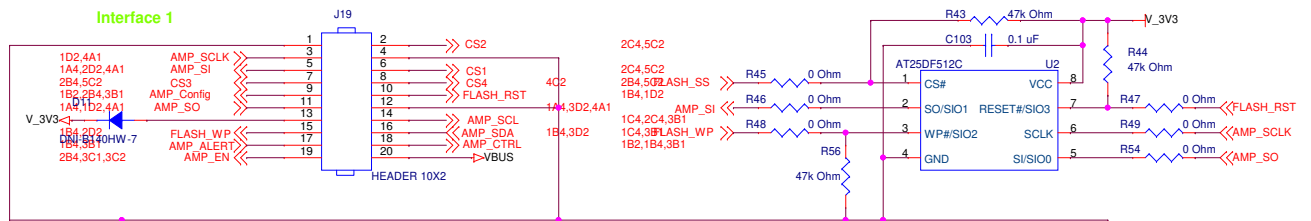

Title		
AmP8DB3 Eval Board V2.0		
Size	Document Number	Rev
B	AMP8DB2_REV2_5X5_ENG_01162022	2.0
Date:	Friday, May 20, 2022	Sheet 2 of 4

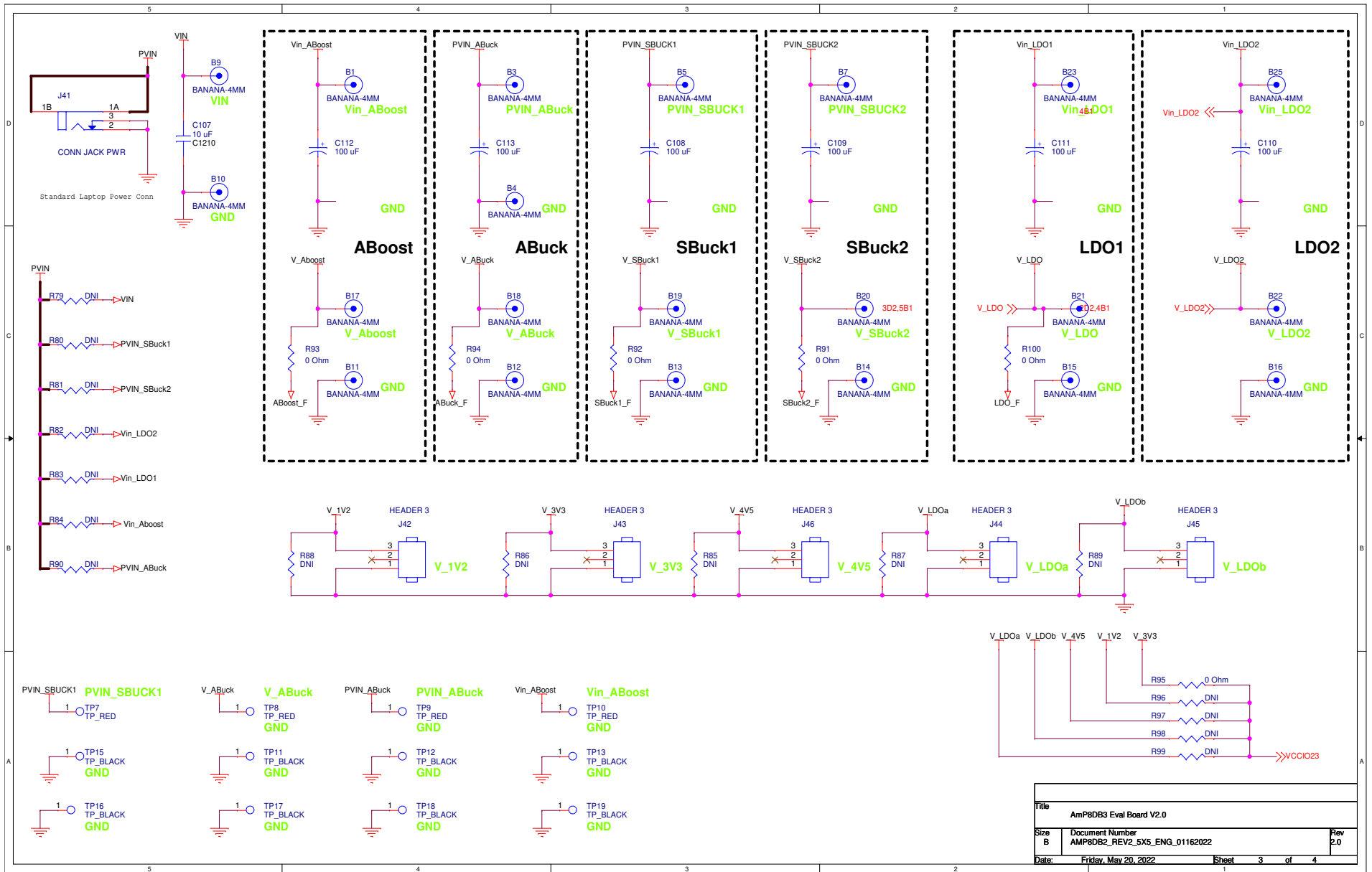

Title		
AmP8DB3 Eval Board V2.0		
Size	Document Number	Rev
B	AMP8DB2_REV2_5X5_ENG_01162022	2.0
Date:	Friday, May 20, 2022	Sheet 3 of 4

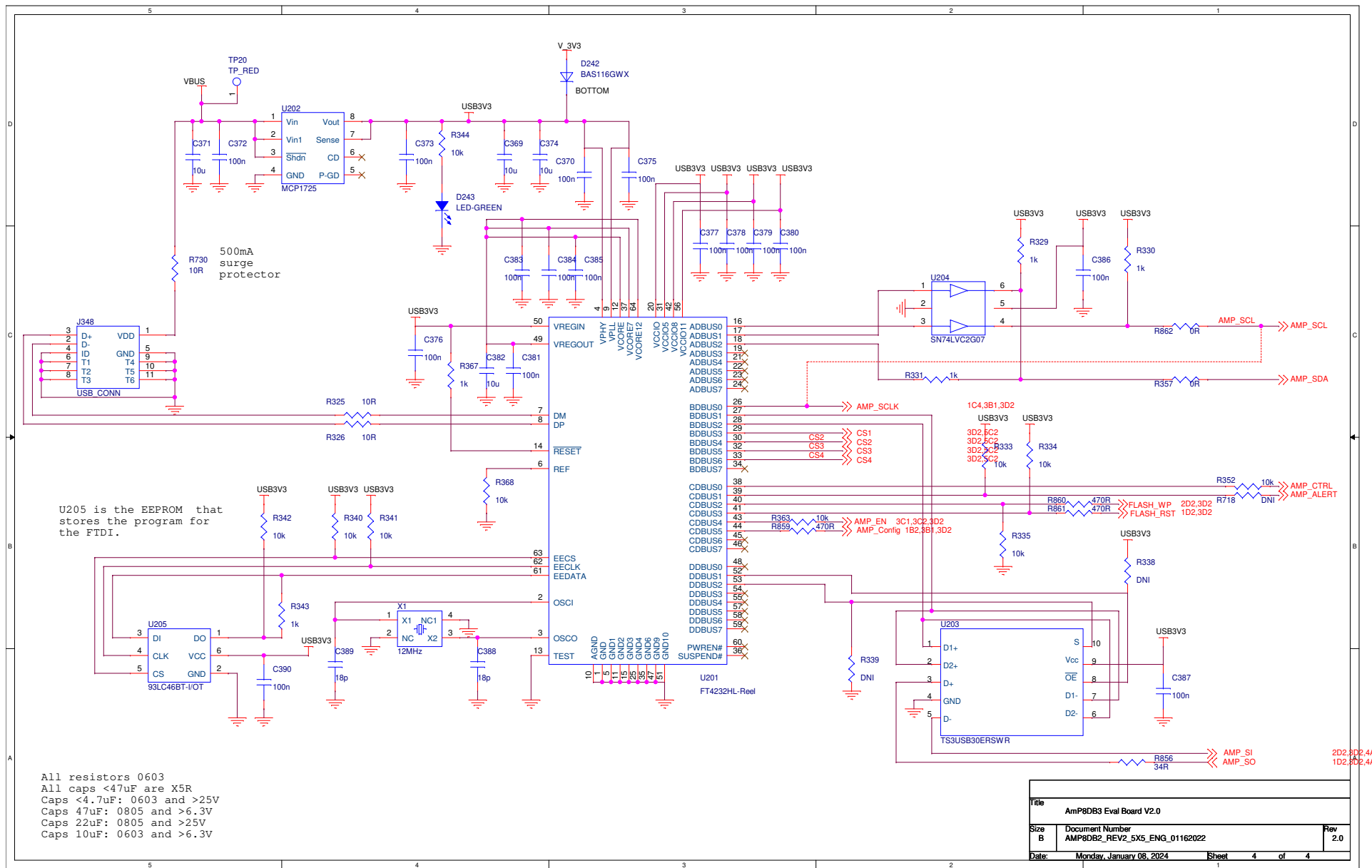

U205 is the EEPROM that stores the program for the FTDI.

All resistors 0603
 All caps <47uF are X5R
 Caps <4.7uF: 0603 and >25V
 Caps 47uF: 0805 and >6.3V
 Caps 22uF: 0805 and >25V
 Caps 10uF: 0603 and >6.3V

Title		
AmpP8DB3 Eval Board V2.0		
Size	Document Number	Rev
B	AMP8DB2_REV2_5X5_ENG_01162022	2.0
Date:	Monday, January 08, 2024	Sheet 4 of 4

2D2,3D2,4A
1D2,3D2,4A

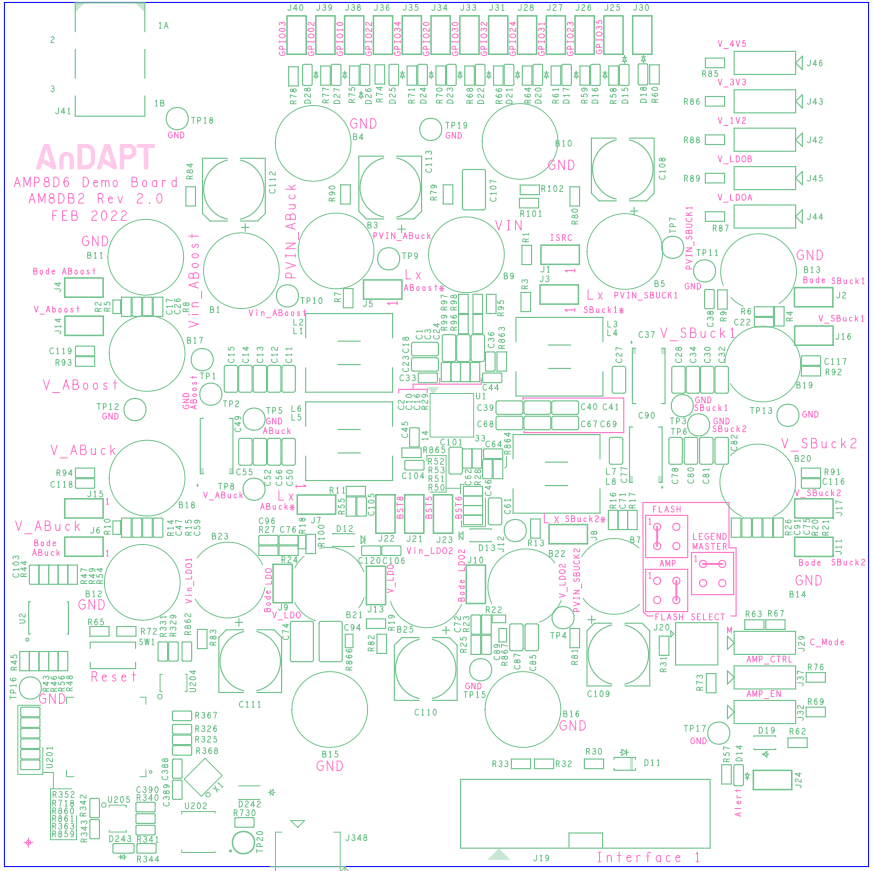

TOP SILK

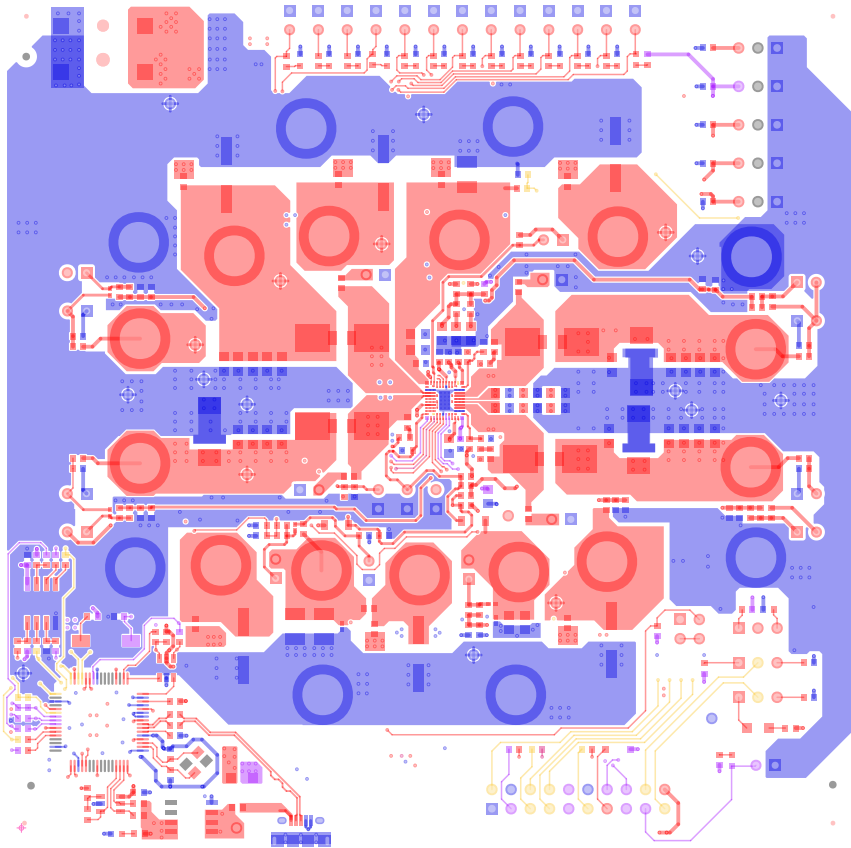

01_TOP

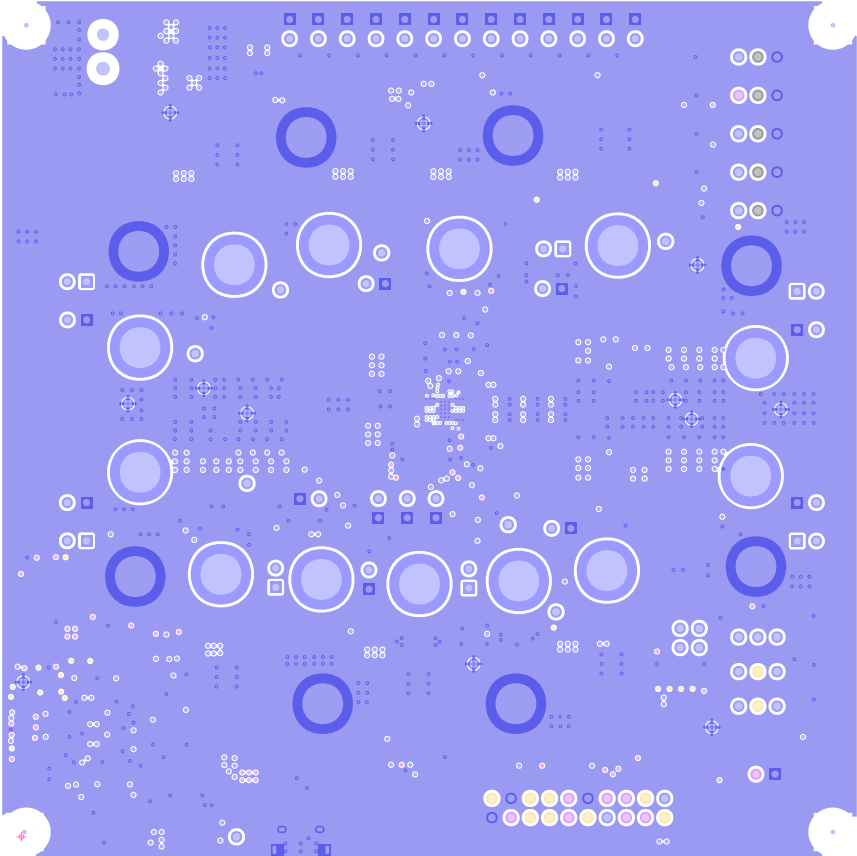

02_GND

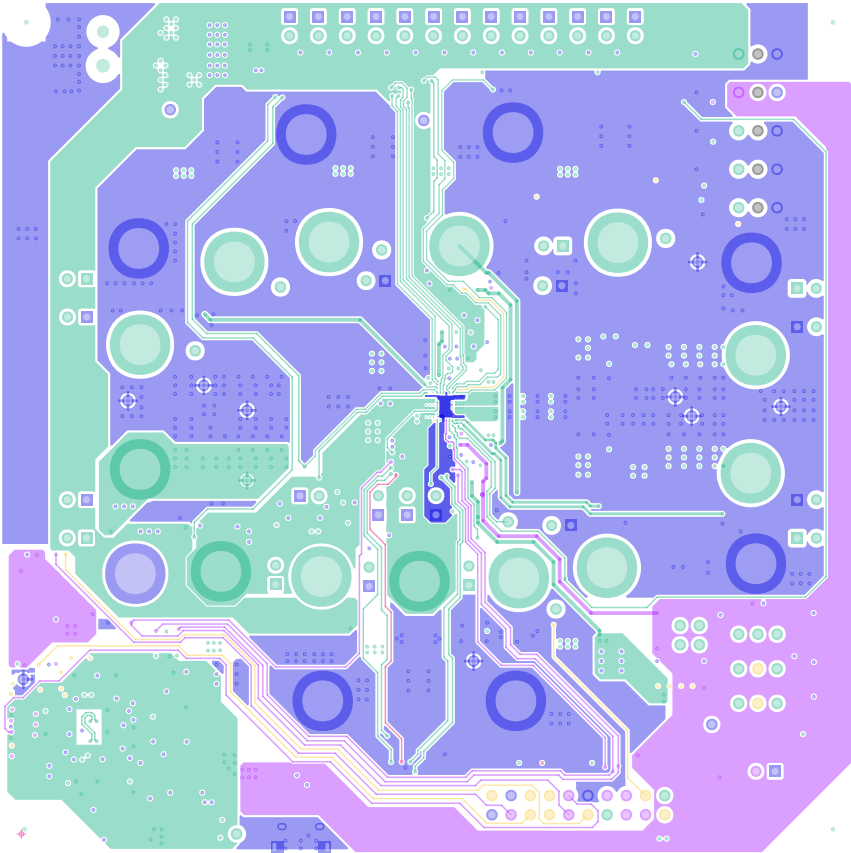

03_PWR

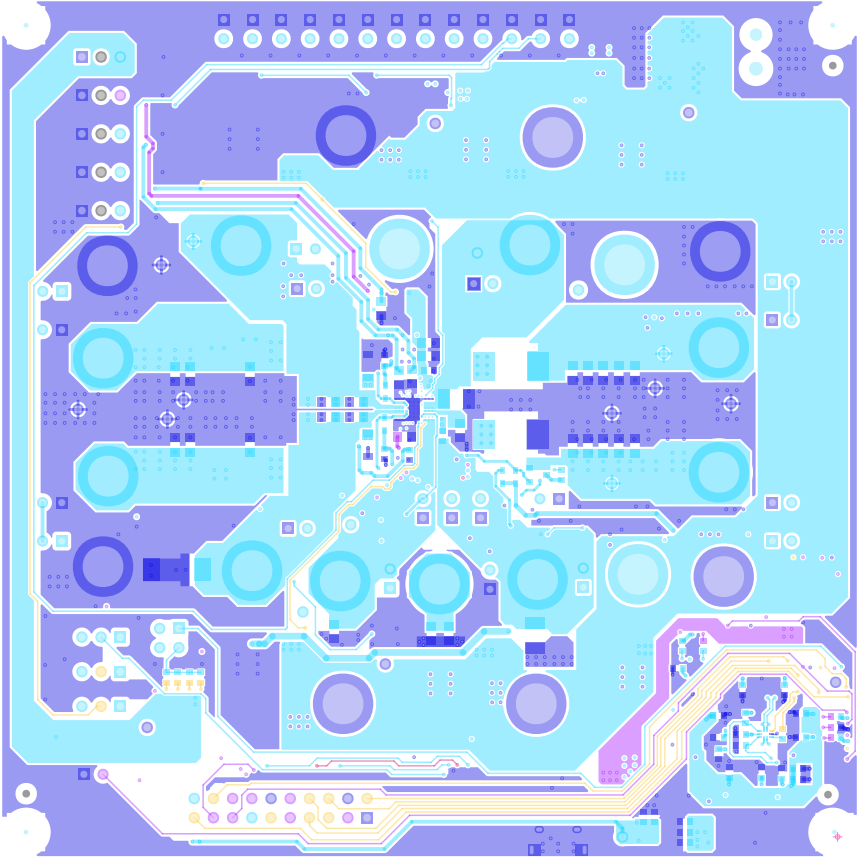

MOTTO8_00

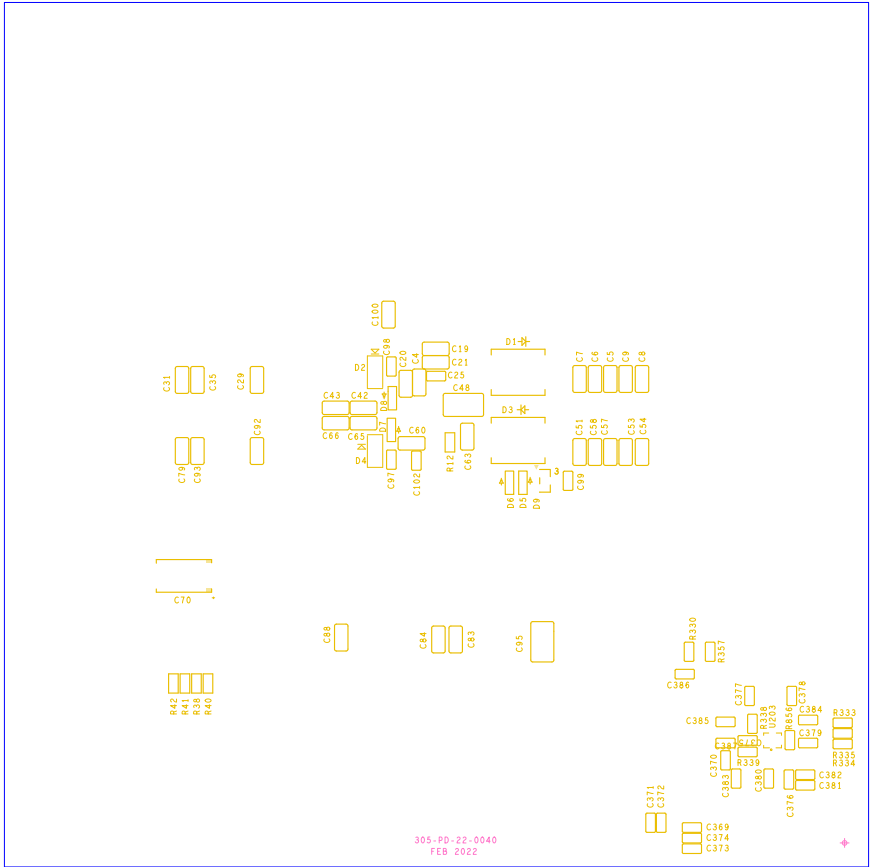

BOTTOM SILK