

### Features

- AmP8DB6QF65 platform 5x5 mm<sup>2</sup> package on board
- Demonstrates Power Components:
  - 2 x Synchronous Buck
  - 2 x Asynchronous Buck
  - 2-phase DrMOS Buck
  - 1-phase DrMOS Buck
  - Multiple LDOs
  - Load Switches
  - Supervisor Functions
- Connects to AmPLink™ USB adapter
- WebAmP Tool Downloads Configuration File
  - .HEX file (Intel HEX) to program on board Flash
  - .HAX file to configure AmP device directly

### Description

The AmP8DB3 is a ready-to-use Demonstration Board to evaluate Power Components on the AmP, Adaptive Multi-Rail Power Platform. Simply drag and drop Power Components (e.g. synchronous buck DrMOS controller), in the online WebAmP design tool, type in the specifications, click the “compile” button in the compile tab, then click the “Program & Verify” button in the AmPLink tab to download the configuration into the AmP8D6QF65 through a USB cable.

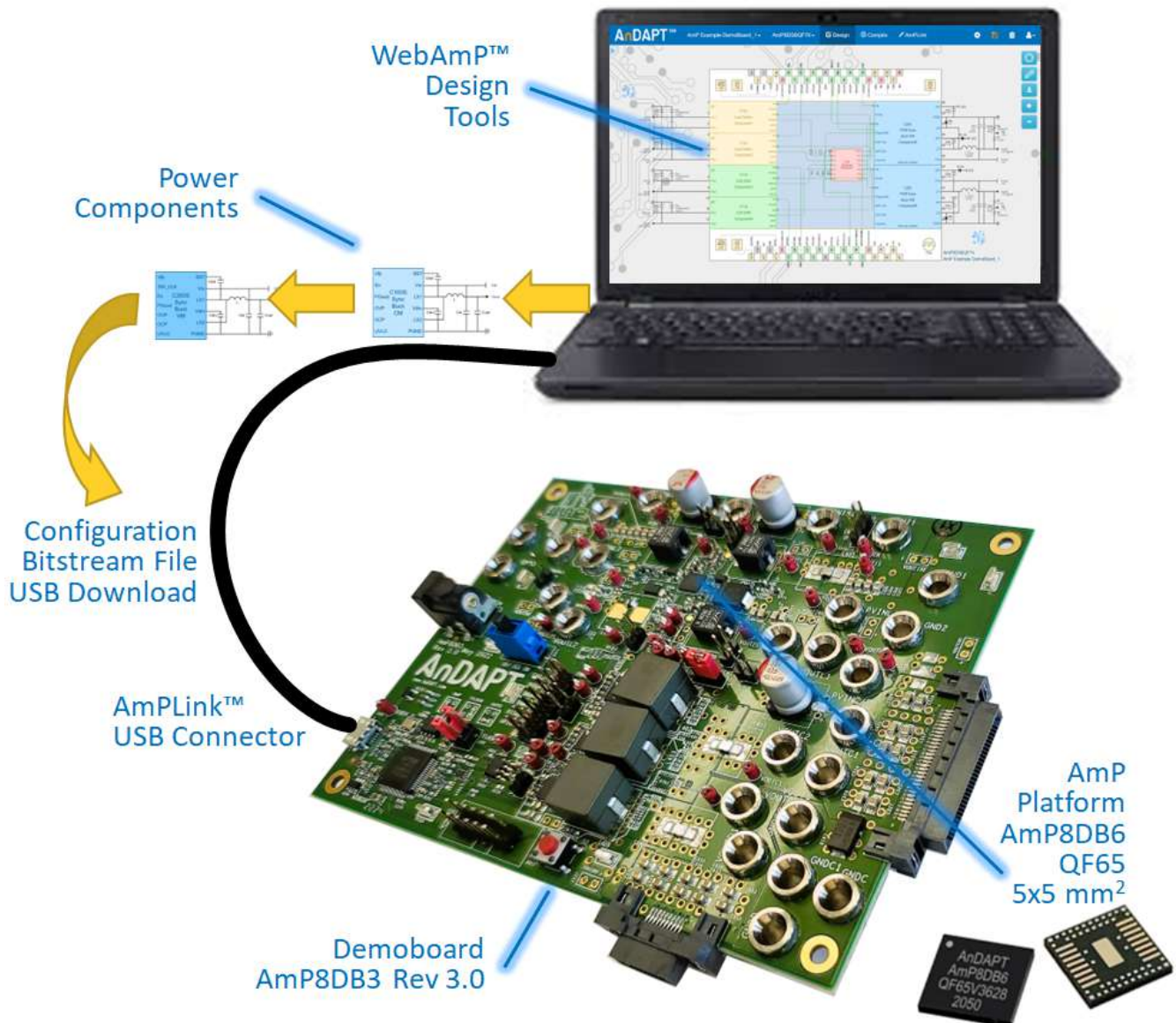

## Quick Start Example

For a quick start example, the AmP chip will be programmed from WebAmP with a synchronous buck converter (C200). See connection diagram and jumper settings as below in Figure 1.

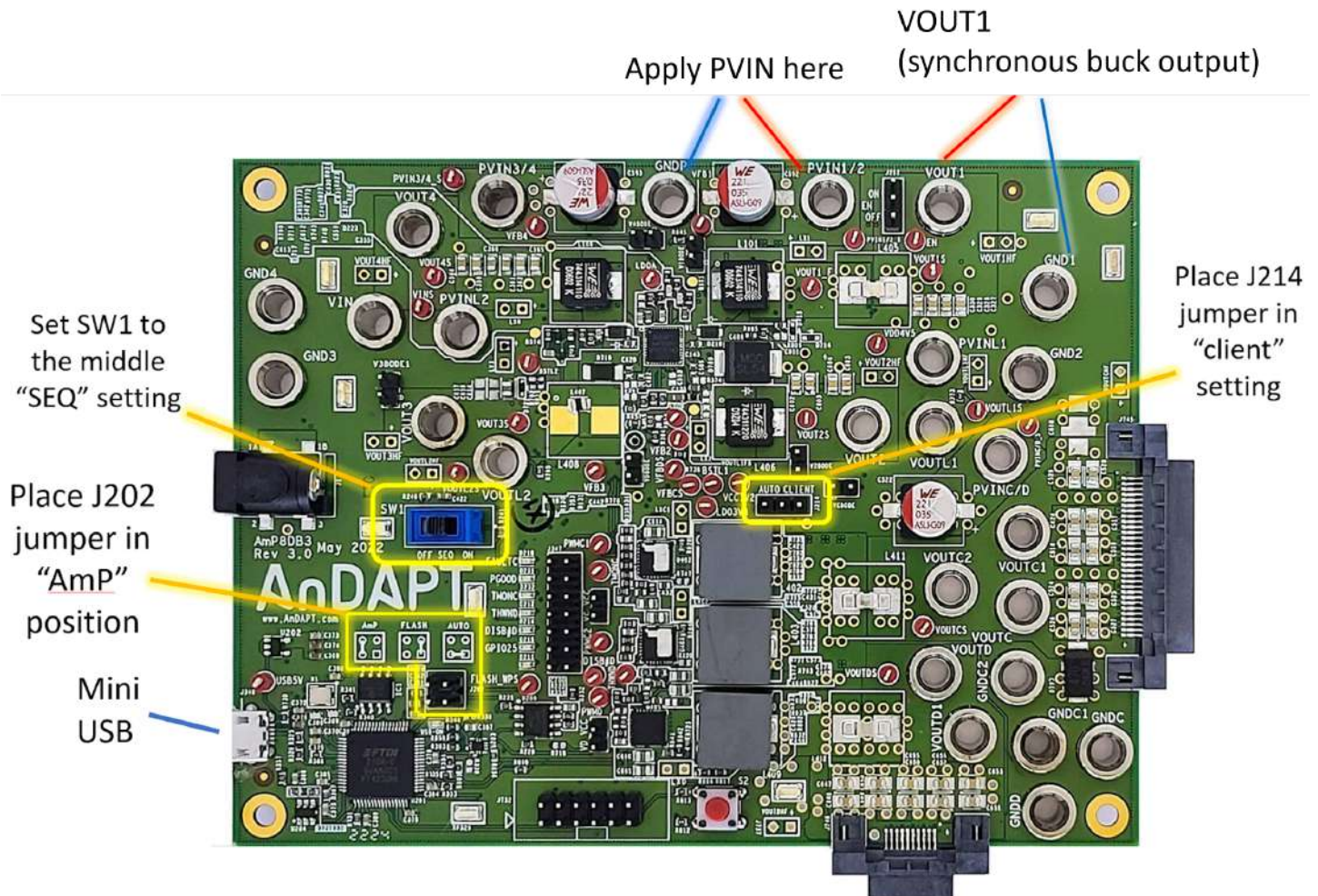

Figure 1: AmP8DB3 demo board showing connections and jumper settings for the Quick Start Example

### Step 1

Set up the jumpers as shown to enable programming the AmP chip directly from the USB cable. Set the 3-position switch SW1 to the middle “SEQ” setting. This allows WebAmP to perform remote on/off. For details see: [AmPLink Config & Cntrl](#)

### Step 2

Connect a 12V bench power supply to PVIN1/2. This is the power to the buck converter whose output is VOUT1. Note the power for the AmP chip internals, VIN, will be powered via OR’ing diodes in the PCB.

### Step 3

Visit <https://webamp1.andapt.com/project> using Google Chrome.

#### Step 3.1

Click the tab “Projects” then *Examples*  *Platform B*  *Demoboard Designs*  *AmP8DB3\_SyncBuck\_QuickStart*. This loads a .JSON (WebAmP configuration file). Then click the tab “Compile” and click the “Compile” button. This compiles the design into a .HAX file which will then be downloaded via the USB cable into the AmP chip.

#### Step 3.2

Click the *AmPLink* tab. Before first time use, click “Download AmPLink Software” which installs a Chrome extension which enables communication with the AmP chip via the USB cable. After this one-time installation, re-load the webpage and repeat Step 3.1. Then click “Program & Verify” in the upper right. If it does not turn green, check the 12V power to the PCB and the USB connection.

Step 4

Power the buck on and off by clicking and toggling the CTRL output below:



Alternatively, push SW1 to the “ON” or “OFF” position to enable or disable the AmP chip. The switch in the ON or OFF position will override the WebAmP CTRL signal.

### Examining and Modifying the Design

Clicking the Design tab will show the design which the user can modify.

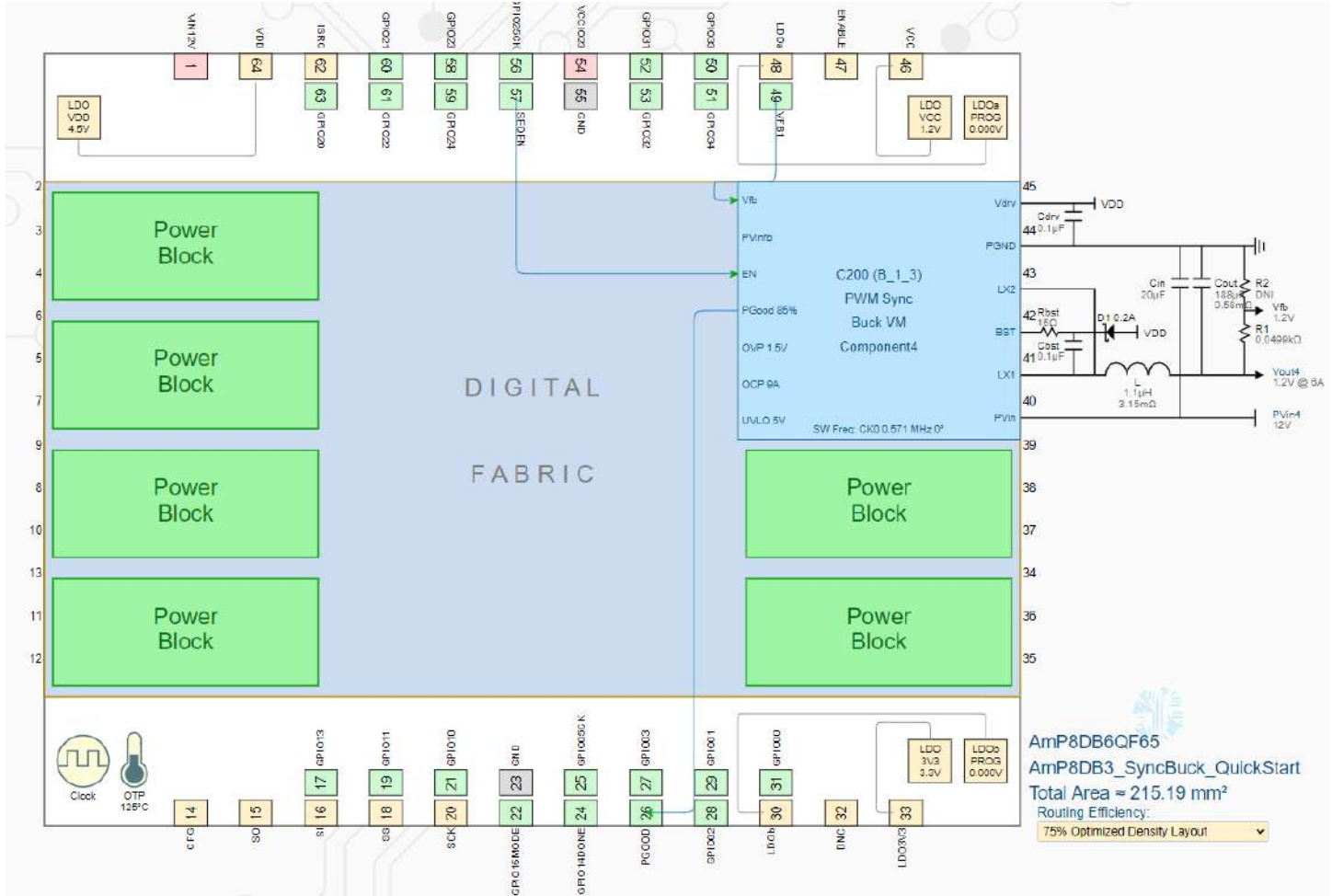

Double clicking the Power Component brings up its specifications.

### Connection Points

#### Power inputs and outputs

The AmP8DB3 board has multiple converters available. See Figure 2. The high current inputs and outputs have banana jacks. The outputs are named “VOUTxx”, and the power inputs are named “PVINxx”. All the high current inputs and outputs have banana jacks. Note that VIN does not require separate power if either PVIN1/2 or PVIN3/4 is powered because diodes on the board will provide power for VIN.

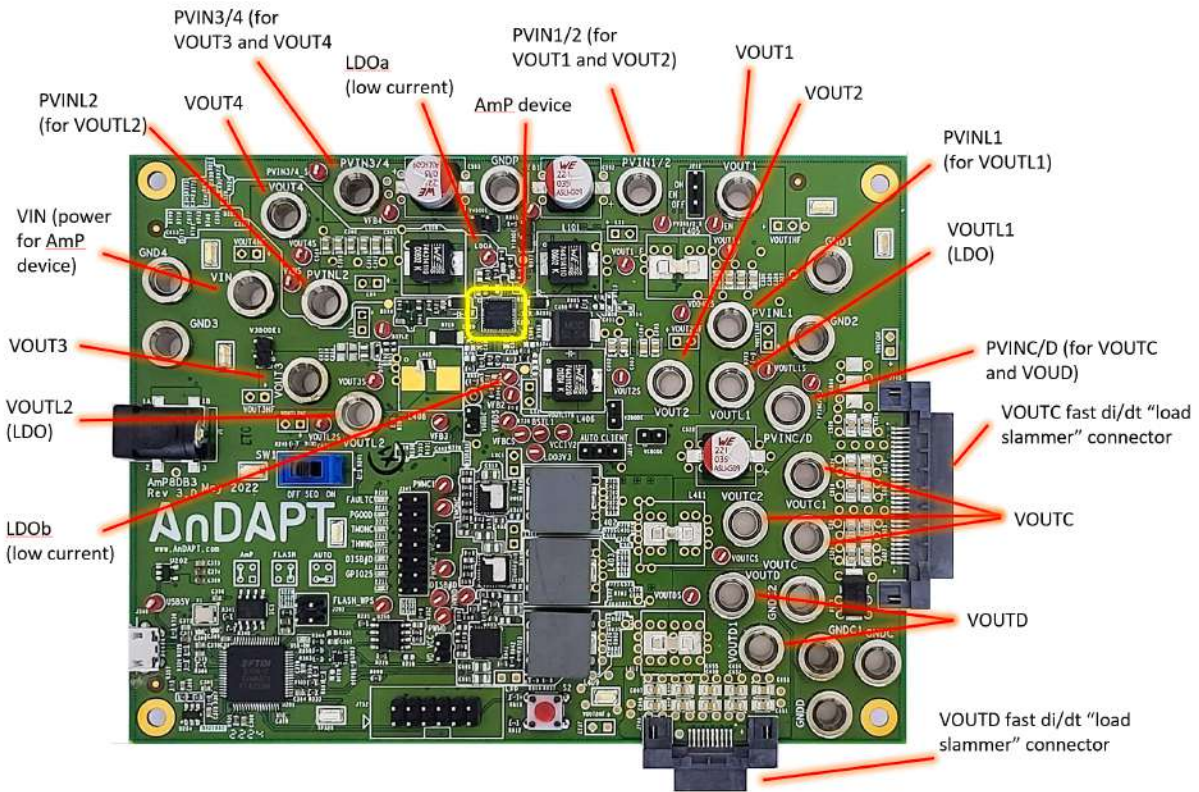

Figure 2: AmP8DB3 board showing power input and output banana jacks, fast di/dt connectors, and LDOa and LDOb eyelet connectors. Note all GROUNDx banana jacks connect to the ground plane

Output name	Converter topology	Max current	Power Component
VOUT1	Synchronous buck	6 A	C200
VOUT2	Asynchronous buck	6 A	C150
VOUT3*	Asynchronous buck	0.1 A	C150
VOUT4	Synchronous buck	6 A	C200
VOUTL1	LDO/LOADSW	3 A (LDO thermally limited) / 6A (LOADSW)	C710/C711/C750/C751
VOUTL2	LDO/LOADSW	3 A (LDO thermally limited) / 6A (LOADSW)	C710/C711/C750/C751
VOUTC	2-phase DrMOS	50 A	C870
VOUTC**	1-phase DrMOS with I <sup>2</sup> C **	30 A	I860**
VOUTD	1-phase DrMOS	30 A	C865
LDOa	Low current LDO	50 mA(?)	LDOa
LDOb	Low current LDO	50 mA(?)	LDOb

\* VOUT3 is not optimized and requires multiple PCB component changes to enable. See the appropriate VOUT3 section below  
 \*\* I860 requires 0Ω resistor jumper changes. See the appropriate I860 section below.

Table 1: List of available converters on the AmP8DB3 board

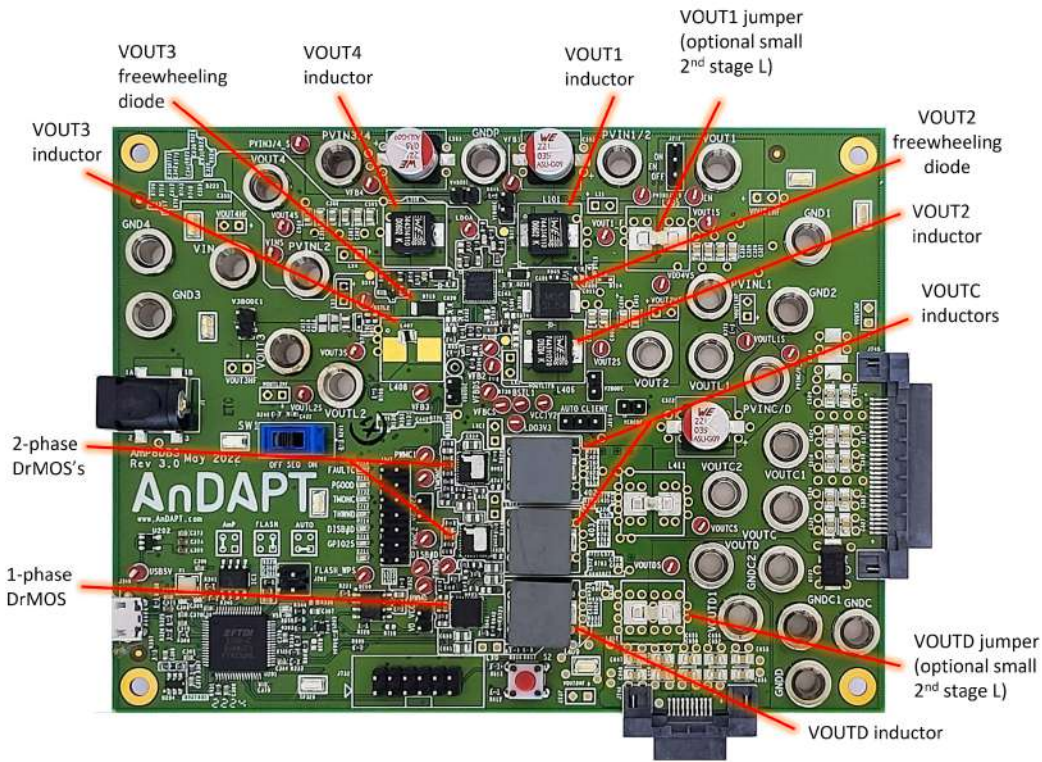

Figure 3: AmP8DB3 board major components

### Grab Points for Oscilloscope Probe Ground Clips

Several grab points are provided for oscilloscope ground clips. Take care to clip firmly because a ground clip coming loose and touching a part of the circuit can damage the AmP device.

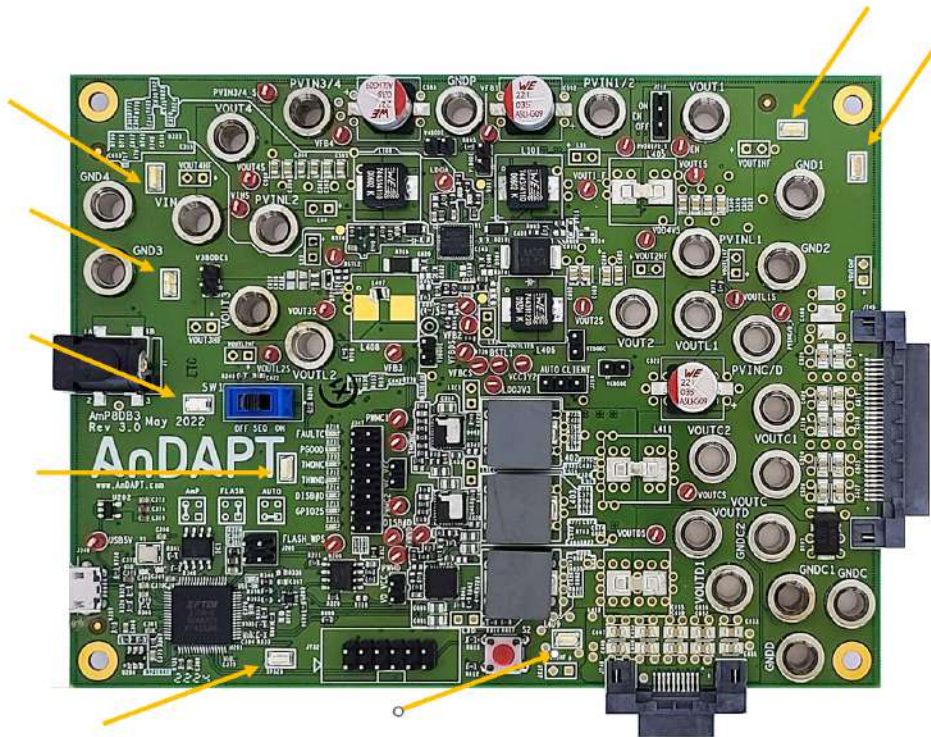

Figure 4: Scope ground clip grab points

### Proper Test Points for Measuring Board Performance

There are various performance measurements that are made on an evaluation board. Many of these measurements require careful connection to the proper points that are often different for various measurements. For example, the best place to sense  $V_{out}$  for ripple or transient testing is different from the point used to measure efficiency. The next few sections will go over the proper test points.

### Voltage Measurement Points

To measure efficiency or regulation on the AMP8DB3 Demo Board accurately, care must be taken to sense the voltages appropriately. The Eval Board has included test points to measure efficiency for each of the switching regulators. See *Figure 5*. Sense points are available for multiple PVIN inputs and outputs.

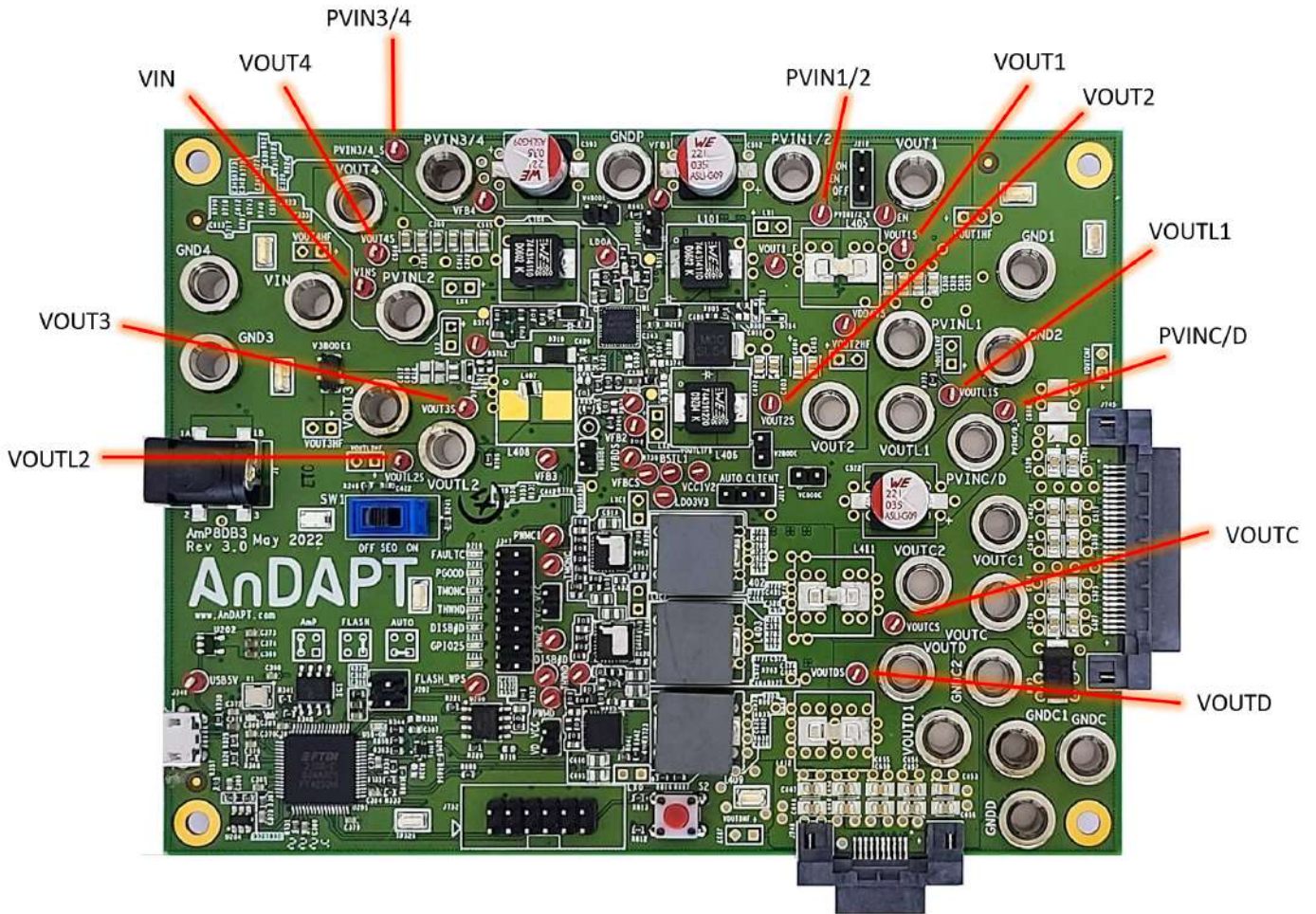

Figure 5: Eyelet clip sense points for Kelvin connections to measure voltages accurately for calculating regulation and efficiency

### Ripple and Transient Response Measurement Points

To measure the output ripple and load transient response voltages, several 2-pin 100-mil header placeholders are provided on the board to enable high frequency measurements with low noise. After soldering in a standard 2-pin header, these can be used to connect directly to an oscilloscope using a standard BNC to female header pin cable. Alternatively, a 2-prong header can be plugged into the cable and inserted into the holes without soldering. These locations are named "VOUTxHF". The headers for each of the switching regulators are shown below. The positive side of the header is labelled '+'. Use care to insert them with the correct polarity otherwise an output can be short circuited through the oscilloscope ground.

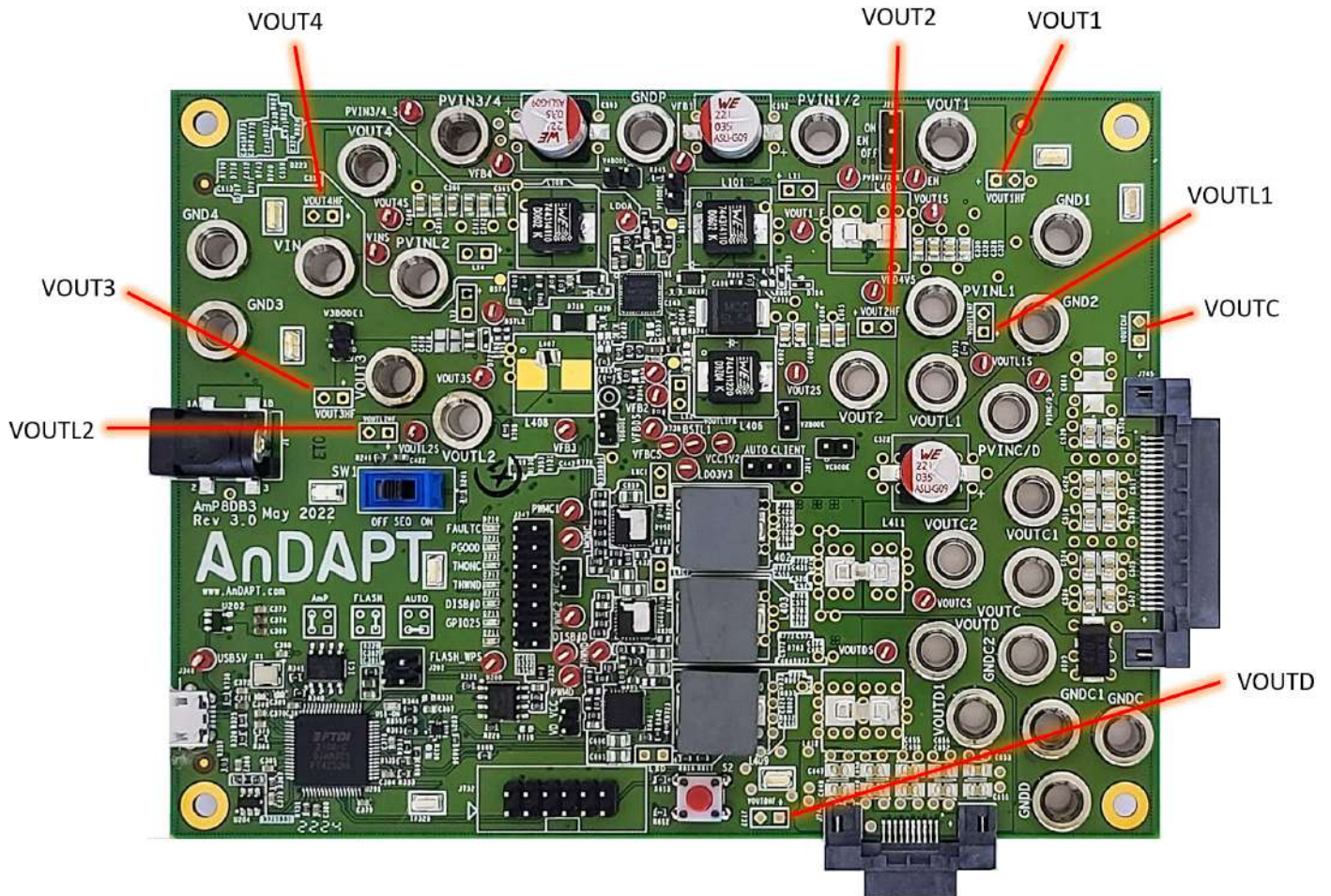

Figure 6: 2-pin headers for measuring output ripple or transient response

### Switching node sense points

Two pin header placeholders are provided for making high frequency measurements of the main switching nodes. They are labeled “VxLX” or “LXx”. The positive side is labeled ‘+’. They have a 953Ω resistor (see below) and are meant to be used with a mating 2-prong plug with a 50 Ω cable, and a 50 Ω terminator or termination on the oscilloscope. The oscilloscope probe attenuation needs to be set to 20X. *Figure 7* shows the locations.

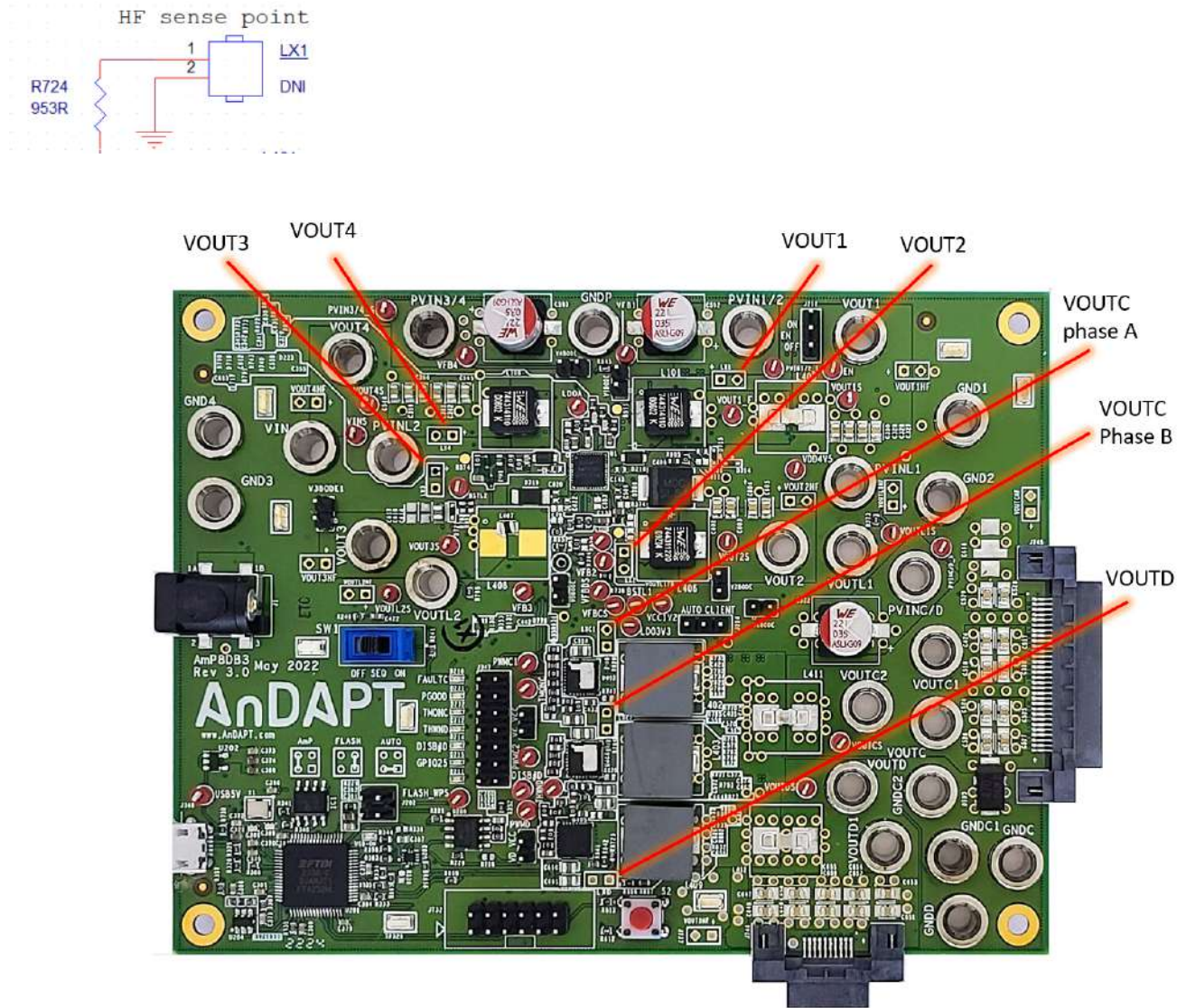

Figure 7: Two-pin header locations for switching node voltage measurements. Use 50 Ω termination at the oscilloscope and set the scope input attenuation to 20X. The headers are labeled “LXx” or VxLX”



### Frequency Response Analyzer Connection Points

For several of the converters, 50 Ω resistors are placed in series with the feedback sense lines for connecting a Frequency Response Analyzer. Two-pin headers are placed across these resistors. The symbol “o” is placed next to the pin whose net is connected to the output voltage. The other pin goes to the AmP device feedback input. When connecting to a Bode analyser, the former connects to the “Test” or “Response” input, and the latter pin connects to the “Reference” or “Stimulus” input. *Figure 8* shows their locations.

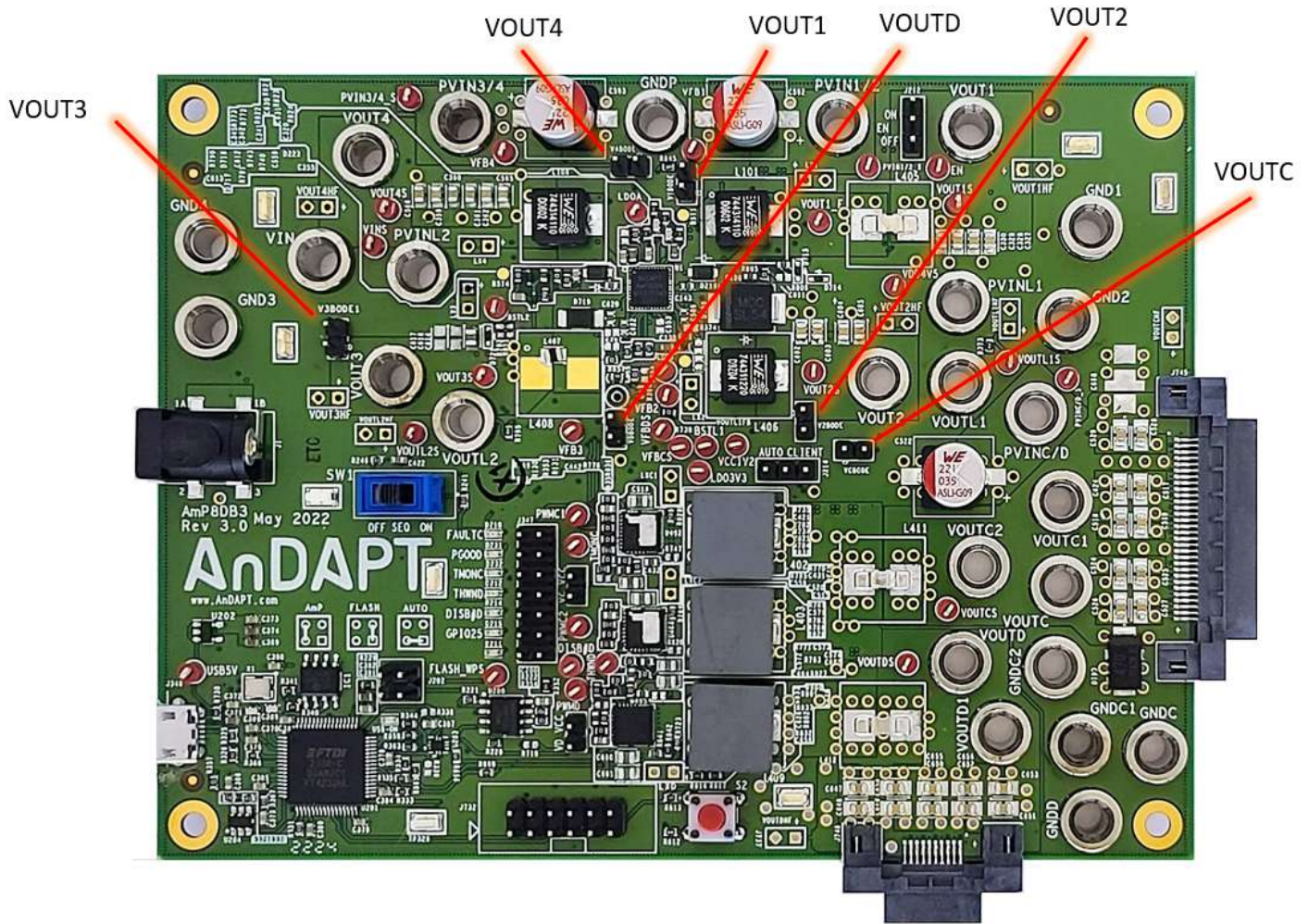

Figure 8: Two-pin header locations of the various outputs for use with a Bode Analyzer. They are labeled “VxBODE”

### Modifications to use a 1-phase DrMOS with I<sup>2</sup>C (I860)

To run an I860, 0Ω jumper R855 needs to be installed. This will assign the GPIO04 to the I<sup>2</sup>C SCL signal and connect it to the 6x2 header connector J732. Removing the 0Ω jumper R854, which connects GPIO04 to the PGOOD LED, is optional.

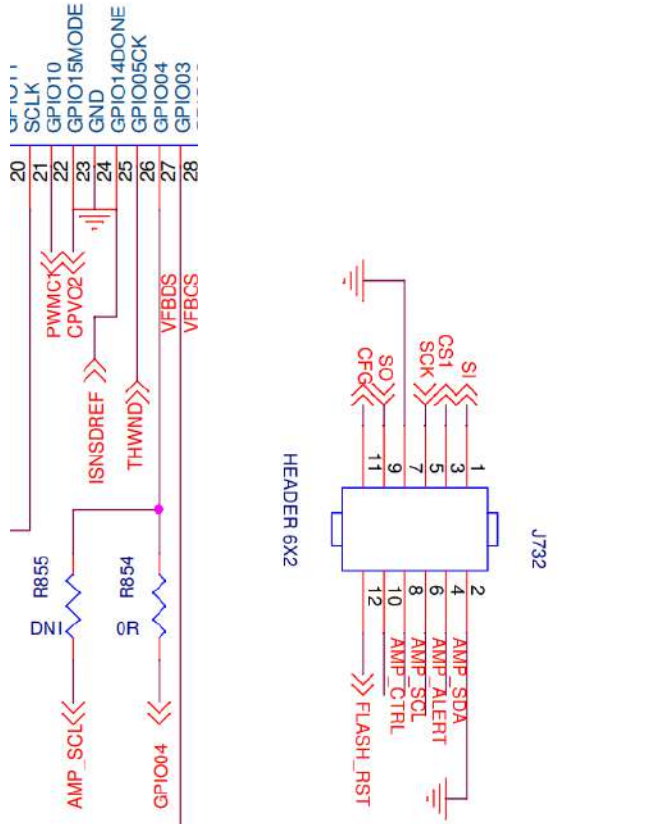

Figure 9: 0Ω resistor jumper locations to allow I860 operation

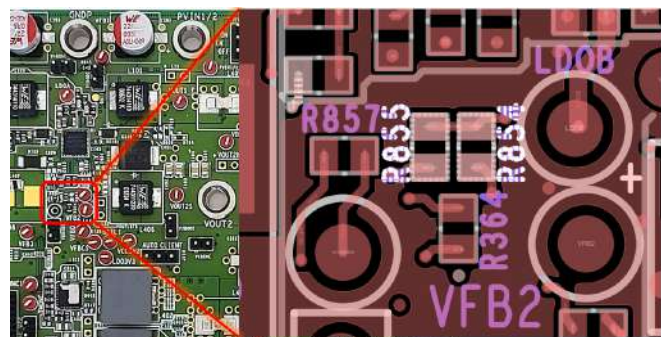

Figure 10: Jumper resistor locations from Figure 9

### Modifications to add external feedback to LDOs VOUTL1 and VOUTL2

LDOs (C710/C711) have the option for external feedback (remote sensing) to improve load regulation despite resistance in the PCB traces.

#### VOUTL1

To allow external feedback for VOUTL1, see Figure 11 and Figure 12 below. Note that this will prevent the use of VOUT3.

- Place a jumper in the RR836 location
- Check that R835 is absent. This will prevent operation of VOUT3
- If the output voltage is > 2.0V, place a lower divider resistor for R374 so that the feedback voltage is close to 2.0V. WebAmp will calculate Vfb for the resistor values.

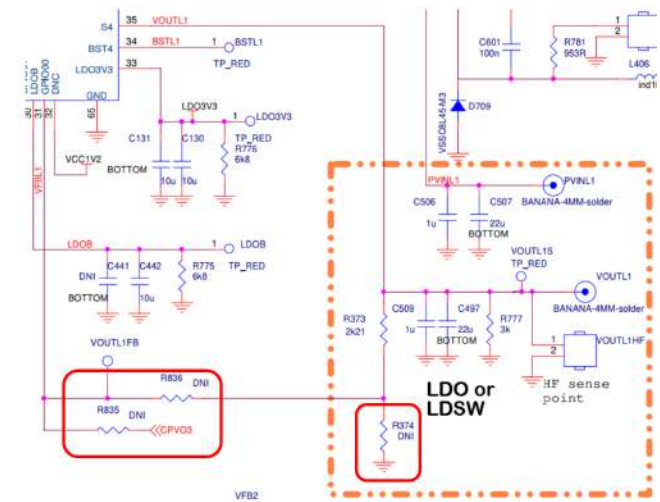

Figure 11: Resistor jumpers that need to be changed to allow remote sensing of VOUTL1.

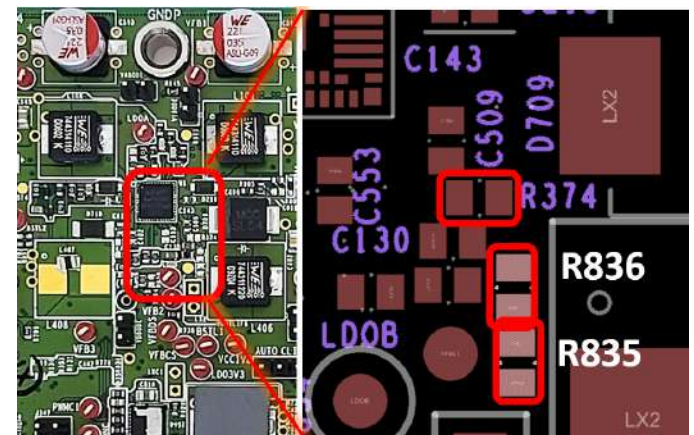

Figure 12: Resistor locations from Figure 11

### VOU2L2

To allow external feedback for VOU2L2, see *Figure 13* and *Figure 14* below. Note this will prevent the use of VOUTD.

- Place a jumper in the R819 location
- Remove R818.
- If the output *voltage* is > 2.0V, place a lower divider resistor for R797 so that the feedback voltage is close to 2.0V. WebAmp will calculate Vfb for the resistor values.

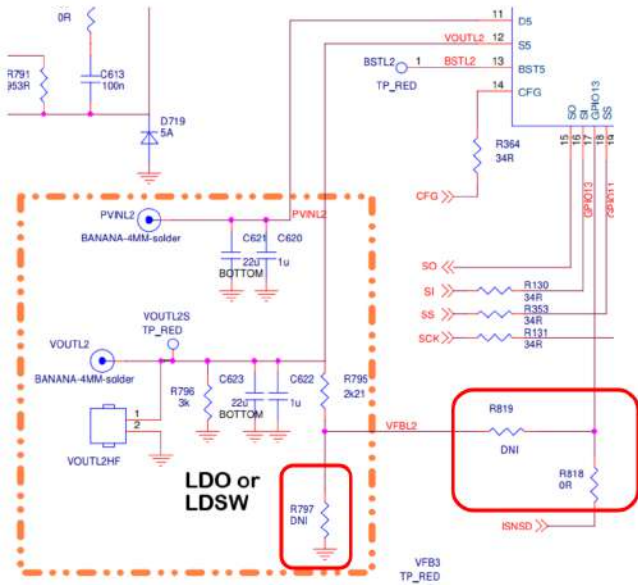

Figure 13: Resistor jumpers that need to be changed to allow remote sensing of VOUTL2. This will prevent prevent VOUTD operation.

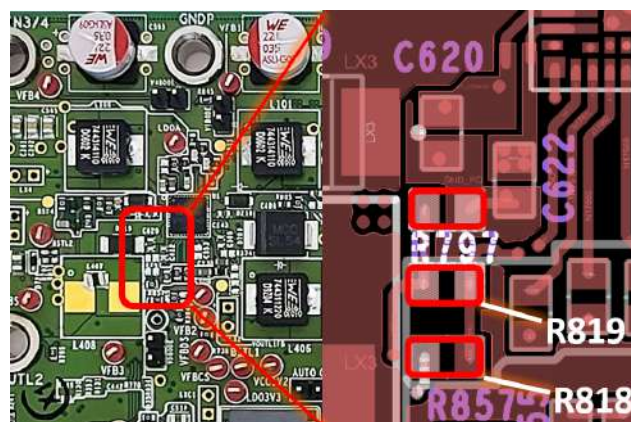

Figure 14: Resistor locations from Figure 13

### Modifications to use VOUT3

To allow the use of VOUT3, see *Figure 15* through *Figure 19*. Note this will prevent the use of VOUTC (2-phase DrMOS) and the use of remote sensing (external feedback mode) of VOUTL1.

- Remove R843 and R836
- Place 0Ω jumper in R835
- Place upper divider resistor in R793 - 50 Ω if Vout <= 2.0V
- if the output voltage is > 2.0V, place lower divider resistor at R794. Use WebAmp to help with calculating the values of

The part values installed are not optimal. The provided .JSON file for VOUT3 will provide 5V at 0.5A but with some significant voltage ripple. To re-design VOUT3:

- Remove the small 2016 sized inductor L407
- Place desired inductor in the position of L408, which is a bigger footprint in parallel with L407.
- Add 0805 47μF capacitors as needed, approximately 1 per 1 to 1.5 A of load current
- Enter the specifications into WebAmp and adjust the feedback loop gains to produce an acceptable Bode response.

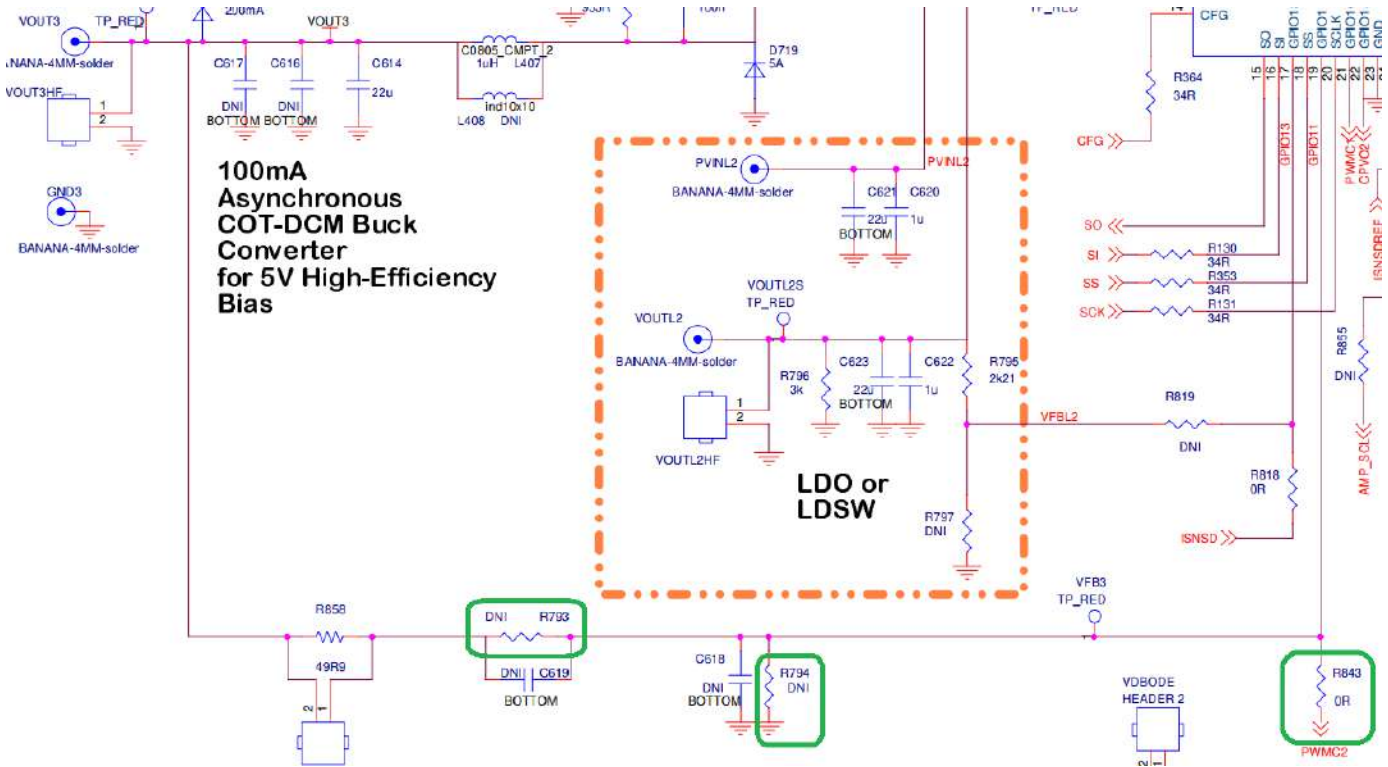

Figure 15: 3 of 5 resistors to modify to enable VOUT3

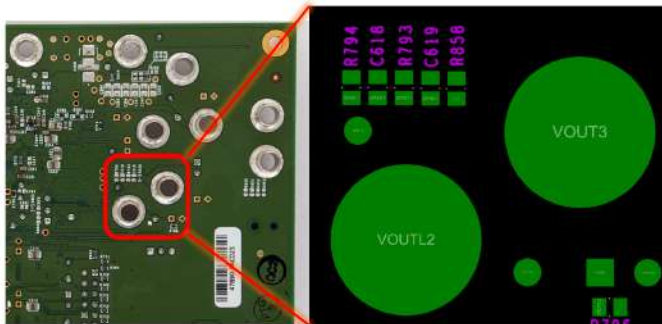

Figure 16: Bottom of PCB: locations of R793 and R794

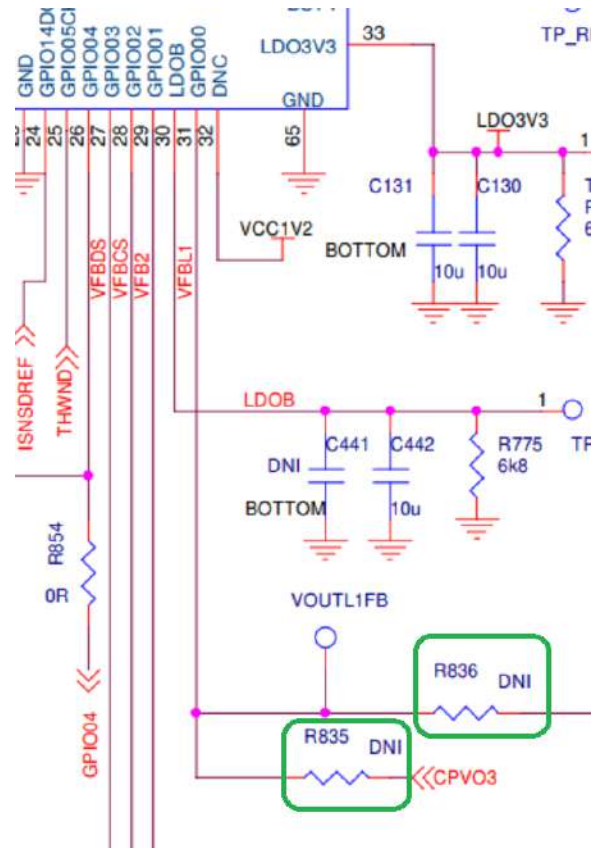

Figure 17: Two of 5 resistors to modify to enable VOUT3

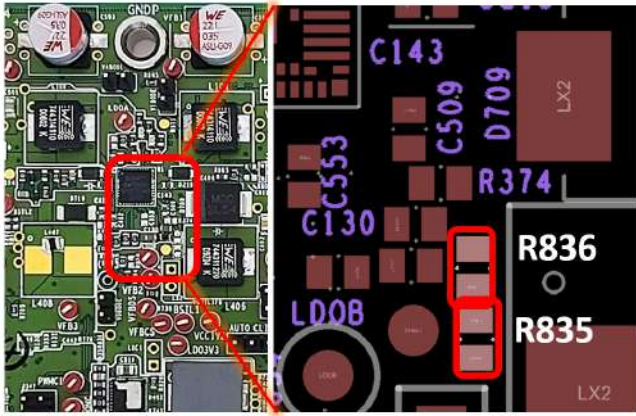

Figure 18: Locations of R835 and R836

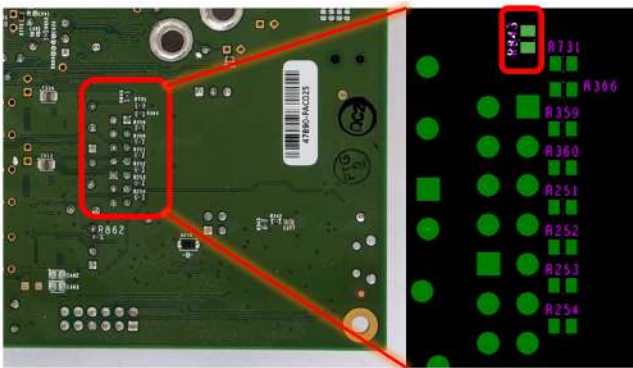

Figure 19: Bottom of PCB: location of R843

### Jumper Configurations

See J202 and J214 locations. Refer to Figure 1.

#### To program the AmP chip from WebAmP online tool

This programs the AmP device directly. The memory is volatile and recycling the VIN power (to the AmP device) requires programming again. Set the jumpers as follows:

J202	J214
<p><b>AmP</b></p>	

In WebAmP, the “Program & Verify” button programs the AmP device via the USB cable:



#### To program the non-volatile flash memory

This programs the non-volatile flash memory so that at power-up, the contents of the flash transfer into the AmP device.

Set the jumpers:

J202	J214
<p><b>FLASH</b></p>	

In WebAmP, after compiling the design, select the AmPLink tab, select the Adesto AT25DF512C in the dropdown list and click “Program & Verify” as below:



After programming the non-volatile memory, follow the instructions under “To run the board from non-volatile flash”

#### To run the board from non-volatile flash

After programming the non-volatile memory, set the jumpers as below so that the board will power up and the AmP device reads its contents. Then toggle SW1 between “ON” and “OFF” to enable the power converters. See Figure 1 for the location of SW1.

J202	J214
<p><b>AUTO</b></p>	

#### Jumpers for use with 1-phase or 2-phase DrMOS

A jumper must be added to provide VCC power for the DrMOS devices. The DrMOS devices are powered from the AmP device’s “VDD4V5” 4.5V internal regulator which comes from the AmP device pin 64. See Figure 20

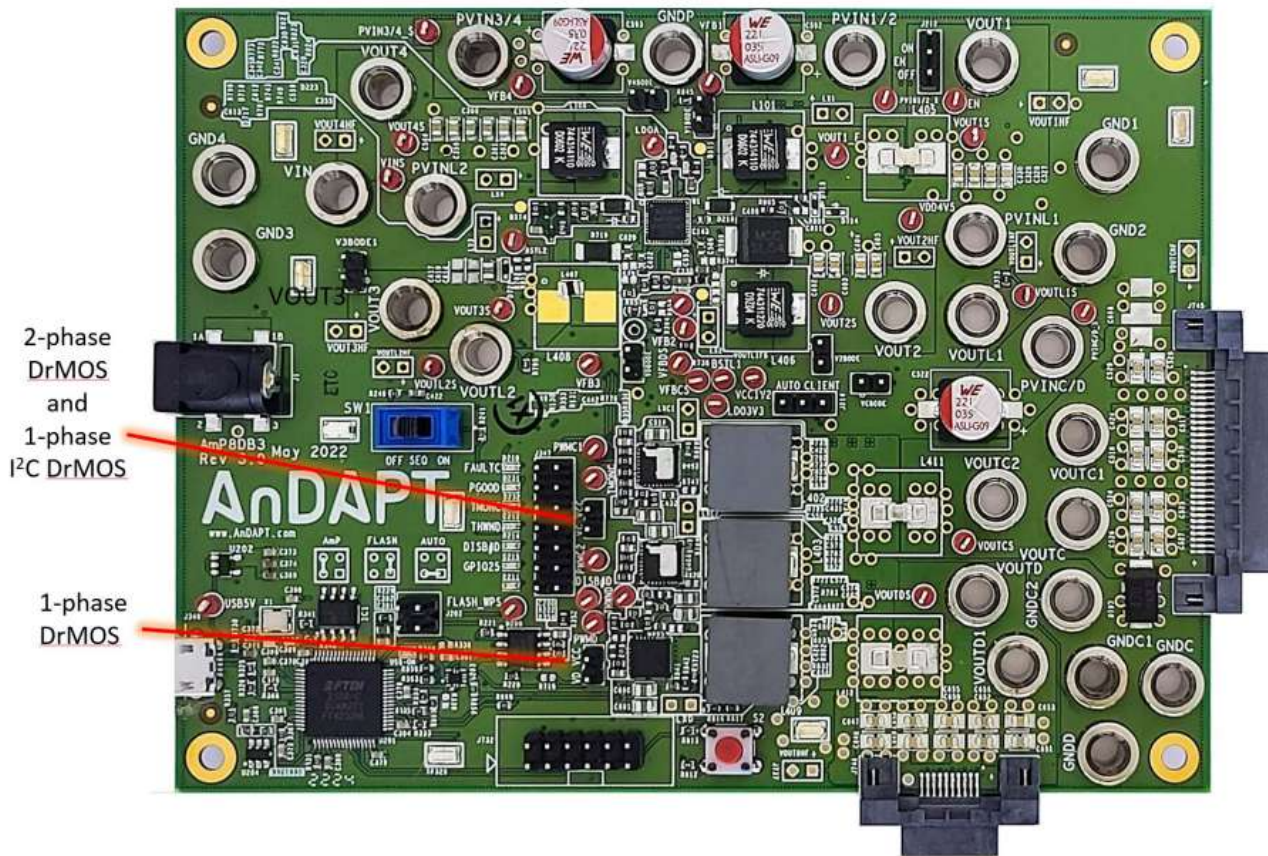
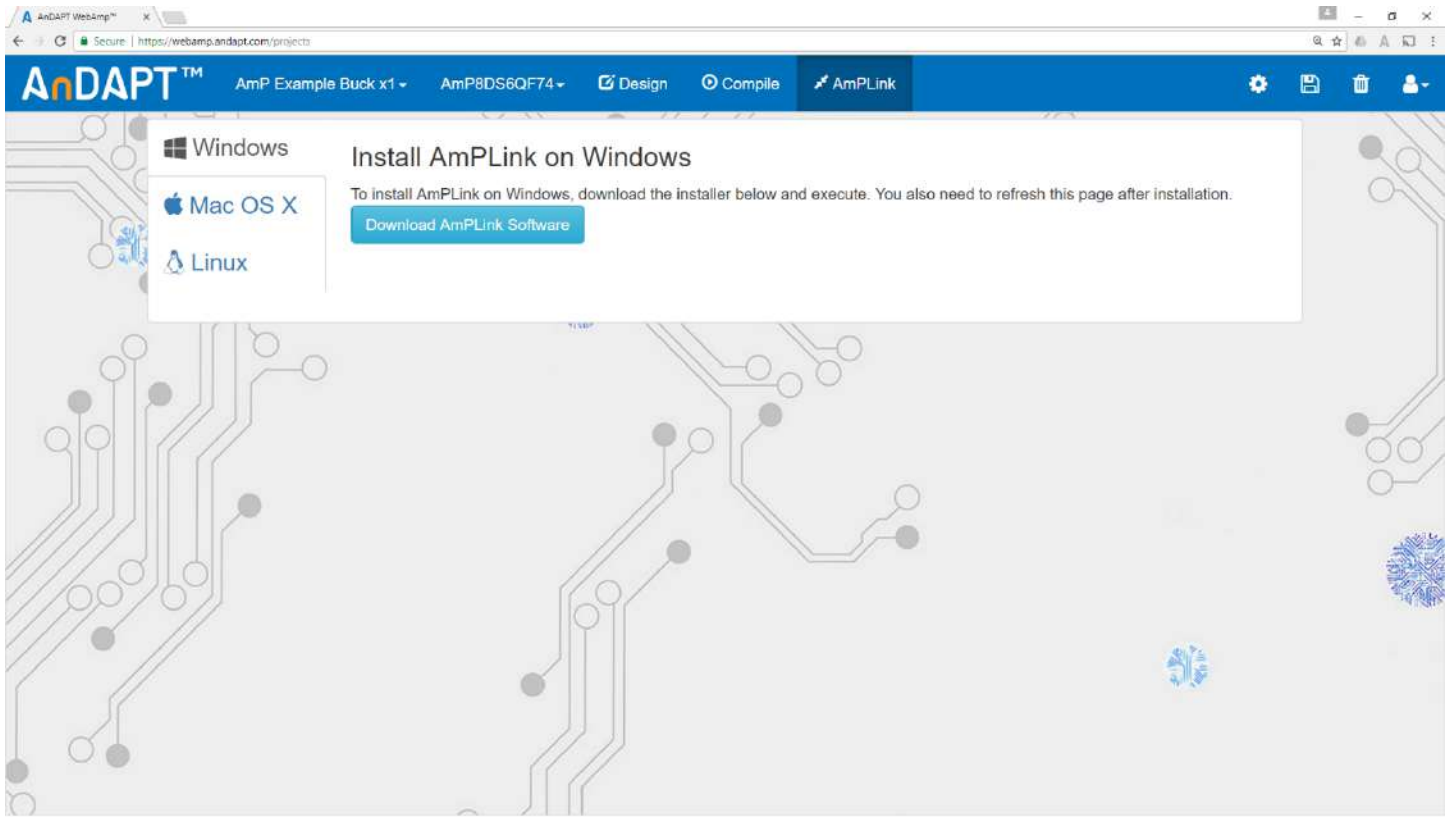

Figure 20: Two-pin header jumper locations for providing VCC power for the 1-phase and 2-phase DrMOS devices. They are labeled “VC\_VDD and VD\_VDD”

## Getting Started with WebAmP: Install AmPLink



# Getting Started with WebAmP: AmPLink Program, Verify & Status

The screenshot displays the AnDAPT WebAmP interface. At the top, there is a navigation bar with the AnDAPT logo and several tabs: 'AmP8DB2\_Buck\_x1', 'AmP8DS6QF65', 'Design', 'Compile', and 'AmPLink'. Below the navigation bar, the main content area is titled 'AmPLink Programming Controls'. It includes a 'Current Project' dropdown menu set to 'Choose File', a project selection dropdown set to 'AnDAPT AMP8D6', and a 'Program & Verify' button. The interface is divided into two main sections: 'AmPLink Interface Controls' and 'AmPScope Interface'.

**AmPLink Interface Controls**

Function	Name	Control
SPI configuration	ENABLE	<input type="checkbox"/> Out <input type="checkbox"/> 0
	CFG	<input type="checkbox"/> In <input type="checkbox"/> 0
FLASH control	WP	<input type="checkbox"/> Out <input type="checkbox"/> 0
	RST	<input type="checkbox"/> Out <input type="checkbox"/> 0
I2C & DVS control	CTRL	<input type="checkbox"/> Out <input type="checkbox"/> 0
	ALERT	<input type="checkbox"/> In <input type="checkbox"/> 0

**AmPScope Interface**

Power Component	Part	Description	Rail	Specification		Actual (I2C/DVS Series Only)										
				Voltage (V)	Current (A)	Enable	Target Voltage (V)	Measured Current (A)	Status							
Component1	C200_A_1_1	PWM Sync Buck VM	Vout1	1.2	6											

Below the table, there is an 'Update' button and a 'Repeat' checkbox. An 'OTP' label is also present in the bottom right corner of the table area.



## Bill of Materials

Item	Qty	Reference	Manuf.	Manuf. PN	Description
1	35	VOUTL1S,VOUT1_F,VOUT1S,VFB1,PWMC1,BSTL1,VOUTL2S,VOUT2S,VFB2,PWMC2,BSTL2,VOUT3S,VFB3,VOUT4S,VFB4,USB5V,VCC1V2,PVIN1/2_S,LDO3V3,PVIN3/4_S,VDD4V5,VOUTDS,VOUTCS,VINS,VFBDS,VFBCS,TMONC,T HWND,PWMD,PVINC/D_S,LDOB,LDOA,FLASH_WPS,EN, DISB#D	Keystone	5000	testpoint red
2	85	VOUTL1HF,VOUTL1FB,VOUT1HF,LXC1,LX1,BST1,VOUTL2HF,VOUT2HF,LXC2,LX2,VOUT3HF,LX3,VOUT4HF,LX4,BST4,C171,R305,R320,C331,R338,R339,C339,C365,C366,R374,L408,C441,C553,C554,C558,C581,C582,C583,C584,C586,C587,C588,C589,C590,C591,C594,C595,C596,C597,C599,C600,C606,C607,C616,C617,C618,C619,C627,C628,C659,C662,C663,C666,R713,R718,J737,R747,R760,R773,R792,R793,R794,R797,R804,R806,R811,R819,R820,R827,R835,R836,R837,R839,R850,R851,R852,R853,R855,VOUTCHF,LXD			DNI
3	2	C37,C609	Panasonic	EEF-LS0D221R	DNI
4	12	C130,C131,C319,C320,C340,C342,C343,C369,C371,C374,C382,C442	Würth	885012107014	10u
5	15	C143,C355,C431,C432,C506,C509,C572,C573,C608,C611,C612,C620,C622,C626,C664			1u
6	18	C144,C353,C356,C357,C497,C507,C513,C514,C515,C516,C520,C574,C614,C621,C623,C660,C661,C665			22u
7	30	C200,C321,C341,C345,C370,C372,C373,C375,C376,C377,C378,C379,C380,C381,C383,C384,C385,C386,C387,C390,C421,C422,C443,C552,C559,C561,C571,C601,C613,C658	Würth	885012206095	100n
8	44	C327,C328,C329,C330,C359,C360,C361,C362,C424,C517,C518,C519,C524,C525,C526,C527,C528,C529,C542,C543,C544,C545,C546,C547,C548,C549,C550,C551,C565,C566,C602,C603,C604,C605,C647,C648,C649,C650,C651,C652,C653,C654,C655,C656	Würth	885012107006	47u
9	1	C344			4u7
10	2	C388,C389			18p
11	3	C522,C592,C593	Würth	865080553014	220u 35V polymer
12	5	C576,C577,C578,C579,C580	Würth	885012107006	DNI
13	2	C610,C667	Panasonic	EEF-GX0E471L	470uF polymer SP-CAP

## Bill of Materials

Item	Qty	Reference	Manuf.	Manuf. PN	Description
14	1	C630	Würth	885012206077	100p
15	1	C631	Würth	885012206077	100p
16	15	C632,C633,C634,C635,C636,C637,C638,C639,C640,C641,C642,C643,C644,C645,C646	Würth	885012107006	DNI
17	1	C657	Panasonic	EEF-GX0E471L	DNI
18	2	C668,C669	Panasonic	EEF-GX0E471L	DNI
19	2	D210,D212	Würth	50060RS75000	LED-RED
20	6	D211,D214,D215,D231,D232,USB-ON	Würth	150060GS75000	LED-GREEN
21	2	D217,D242	Nexperia	BAS116GWX	diode SOD123
22	2	D218,D223	MCC	SMD34PL	Schottky 3A 40V SOD123
23	13	D221,D704,D706,D707,D710,D711,D712,D714,D715,D716,D717,D718,D721	Panjit	RB521S30_R1_00001	Schottky 0.2A 30V SOD523
24	1	D709	Vishay		Schottky 5A 45V DO2214
25	1	D719	Nexperia	PMEG3050EP,115	Schottky 5A 30V SOD128
26	26	VOUTL1,VOUTD1,VOUTC1,VOUT1,PVINL1,GNDC1,GND1,VOUTL2,VOUTC2,VOUT2,PVINL2,GNDC2,GND2,VOUT3,GND3,VOUT4,GND4,PVIN1/2,PVIN3/4,VOUTD,VOUTC,VIN,PVINC/D,GNDD,GNDC	Keystone	575-8	banana jack solder
27	1	GPIO30	Keystone	5000	DNI
28	1	IC1	Microchip	93LC46B-/SN	EEPROM SPI
29	1	J1	Würth	694108106102	CONN JACK PWR
30	1	J202	Würth	61300421121	HEADER 2X2
31	2	J212,J214	Würth	61300311121	HEADER 3
32	1	J347			HEADER 7X2
33	1	J348	Amphenol	10118194-0001 LF	USB_CONN
34	1	J732			HEADER 6X2
35	1	J745	Samtec	HSEC8-130-01-L-D-EM2	edge connector
36	1	J746	Samtec	HSEC8-110-01-S-D-EM2	edge connector
37	2	L101,L108	Würth	744314110	1.1uH
38	3	L402,L403,L409	Würth	744301025	250nH
39	3	L405,L411,L412	Harwin	S1911-46R	jumper

40	1	L406	Würth	744311220	2.2uH
41	1	L407	Würth	74479276210C	1uH
42	5	R130,R131,R353,R364,R856			34R
43	8	R220,R221,R222,R240,R242,R245,R247,R354			47k
44	1	R229			470

## Bill of Materials

Item	Qty	Reference	Manuf.	Manuf. PN	Description
45	14	R241,R246,R329,R330,R331,R343,R367,R782,R783,R784,R785,R817,R840,R841			1k
46	23	R251,R252,R253,R254,R333,R334,R335,R340,R341,R342,R344,R352,R359,R360,R363,R366,R368,R731,R813,R816,R842,R857,R862			10k
47	5	R306,R319,R373,R780,R795			2k21
48	32	R311,R357,R734,R735,R736,R738,R740,R741,R743,R761,R763,R766,R770,R771,R772,R778,R790,R800,R801,R802,R805,R818,R825,R826,R832,R833,R834,R838,R843,R846,R849,R854			0R
49	3	R325,R326,R730			10R
50	6	R712,R803,R844,R845,R848,R858			49R9
51	7	R723,R724,R742,R764,R781,R791,R828			953R
52	2	R775,R776			6k8
53	2	R777,R796			3k
54	1	R779			3k32
55	1	R812			2k2
56	4	R821,R822,R823,R824			100R
57	3	R859,R860,R861			470R
58	1	SW1	Apem	TG39P000000	3 position switch
59	1	S2	TE Connectivity	1825910-7	push button
60	8	TP324,TP325,TP329,TP330,TP331,TP332,TP333,TP334	Keystone	5019	clip point
61	1	U1	AnDAPT	AMP8DB6QF65	PMIC
62	1	U200	Adesto	AT25DF512C-SSHN-T	flash mem SPI
63	1	U201	FTDI	FT4232HL	USB interface IC
64	1	U202	ROHM	BU33SD5WG-TR	LDO 3v3
65	1	U203	TI	TS3USB30ERSWR	USB switch Mux

66	1	U204	Diodes Inc	74LVC2G07W6-7	Line Driver
67	2	U402,U406	Vishay	SiC645A	DrMOS w IMON
68	1	U405	Alpha & Omega	AOZ5311	DrMOS
69	8	V1BODE,V2BODE,V4BODE,V3BODE1,VD_VCC,VDBODE,VC_VCC,VCBODE			HEADER 2
70	1	X1	Würth	830070868	Crystal 12MHz

## Additional Resources

- [Resource Center](#)
- [How-to Videos](#)
- [AmP Platform B Datasheet](#)
- [AmPLink USB Adapter Datasheet](#)
- [AmPLink Configuration and Control](#)
- [Access WebAmP](#)

## Revision History

Date	Revision
07/28/2022	Initial Release
05/16/2023	Corrected typo "i865" "i860"
9/29/2023	Fixes include programming header configuration change, video links, programming literature addition, general formatting

# AnDAPT

## On-Demand Power Management

<https://www.andapt.com>

### Trademarks

© 2022 AnDAPT, the AnDAPT logo, AmP, WebAmP, AmPLink, AmPScope and other designated brands included herein are trademarks of AnDAPT in the United States and other countries. All other trademarks are the property of their respective owners.

All resistors 0603  
 All caps <47uF are X5R  
 Caps <4.7uF: 0603 and >=25V  
 Caps 47uF: 0805 and >=6.3V  
 Caps 22uF: 0805 and >=25V  
 Caps 10uF: 0603 and >=6.3V

Cu thickness is 20z  
 6 layers - #2 and #5 is GND plane

### 6A Buck Converter with option for COT Operation

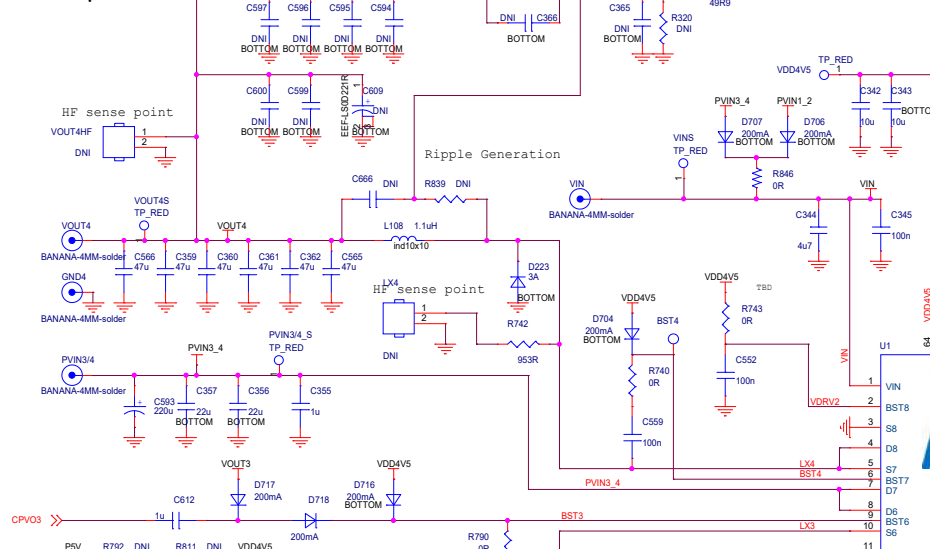

### 6A Buck Converter with option for 2LC ripple reduction

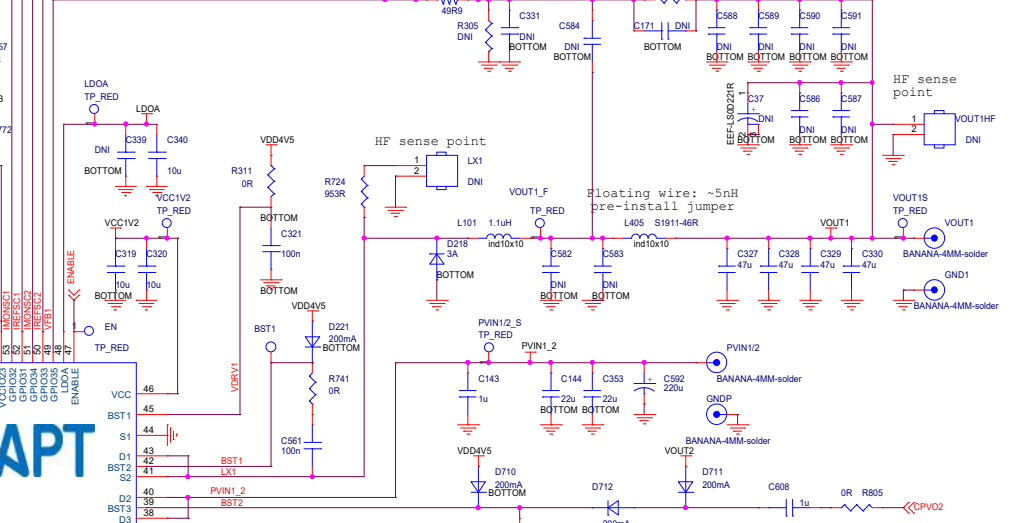

### 100mA Asynchronous COT-DCM Buck Converter for 5V High-Efficiency Bias

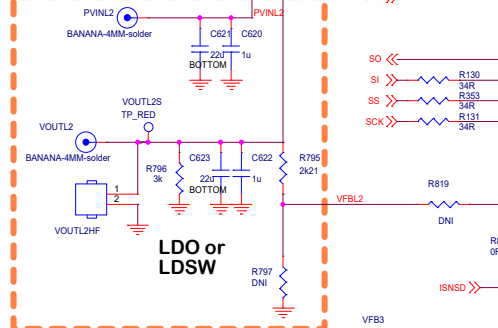
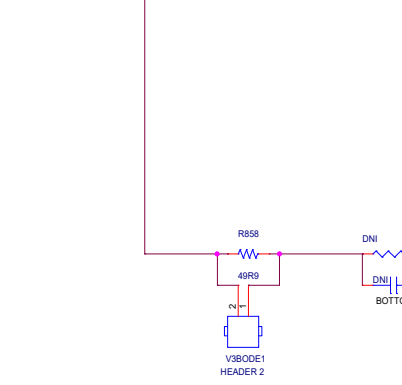

### 6A Asynchronous Buck Converter with option for 100% Duty Cycle

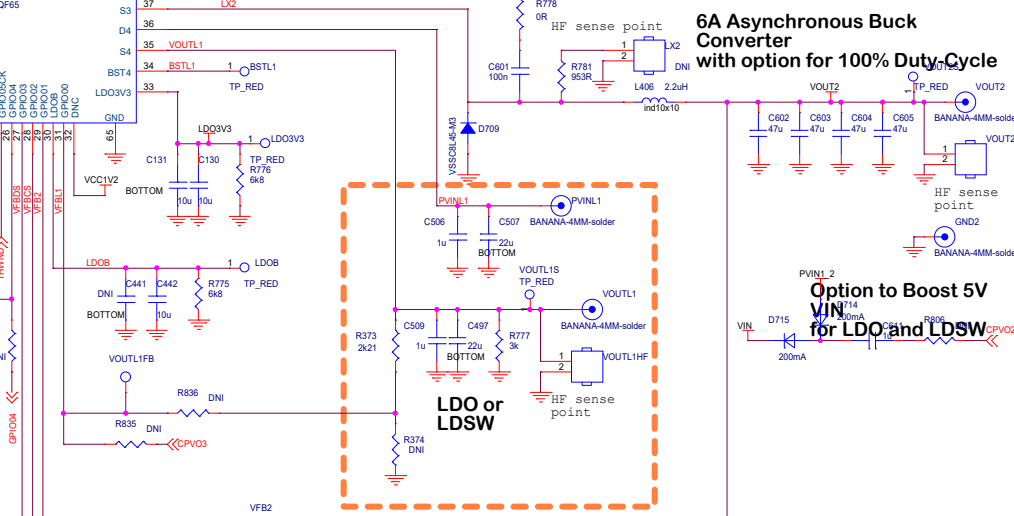

### Option to Boost 5V VIN for LDO and LDSW

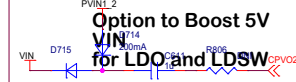

3k32 & 2k21 --> Vfb=2V, best for Vo=5V

Title	AmP8DB3 Eval Board V3.0	
Size	Document Number	Rev
C	AmP8DB3-V3.0.pdf	1.1
Date	Thursday, June 30, 2022	Sheet 1 of 5

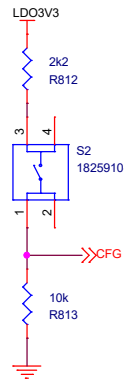
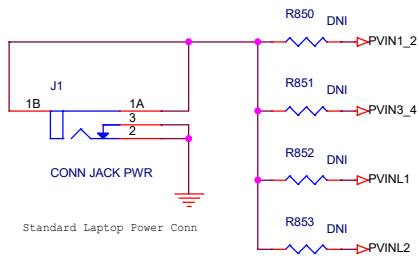

GPIO Assignments

GPIO#	Name	GPIO#	Name
00	VFBL1, CPV03	20	VFBL4
01	VFBL2	21	PWMD
02	VFBCS	22	DISB#D
03	VFBD5	23	TMONC
04	PGOOD, AMP_SCL	24	FAULTC
05	THWND	25	SDA, GL, GPIO25
10	PWMC1	30	SEQEN
11	PWMC2, VFB3	31	IREFC1
		32	IMONC1
13	ISNSD, VFBL2	33	IREFC2
14	ISNSDREF	34	IMONC2
15	CPV02	35	VFB1

All resistors 0603  
 All caps <47uF are X5R  
 Caps <4.7uF: 0603 and >25V  
 Caps 47uF: 0805 and >6.3V  
 Caps 22uF: 0805 and >25V  
 Caps 10uF: 0603 and >6.3V

Connect: Function:

- 1-3 Flash (Program the Flash from AmPLink)
- 1-2 Auto (Part boots from Flash/ROM)
- 2-4 AmP (Part is programmed from AmPLink)

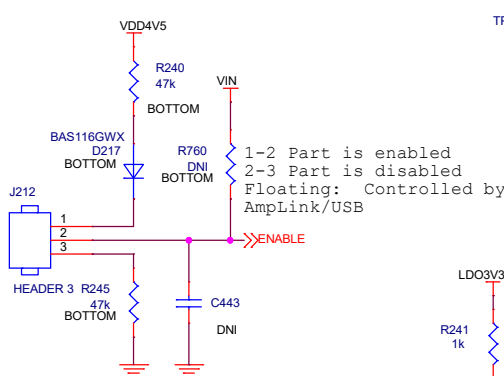
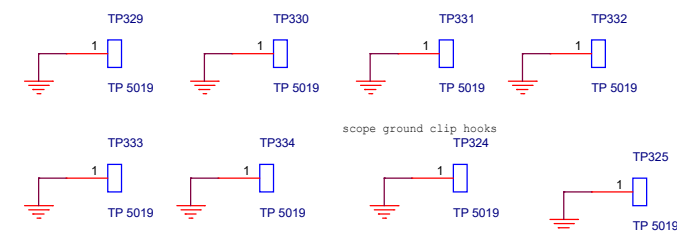
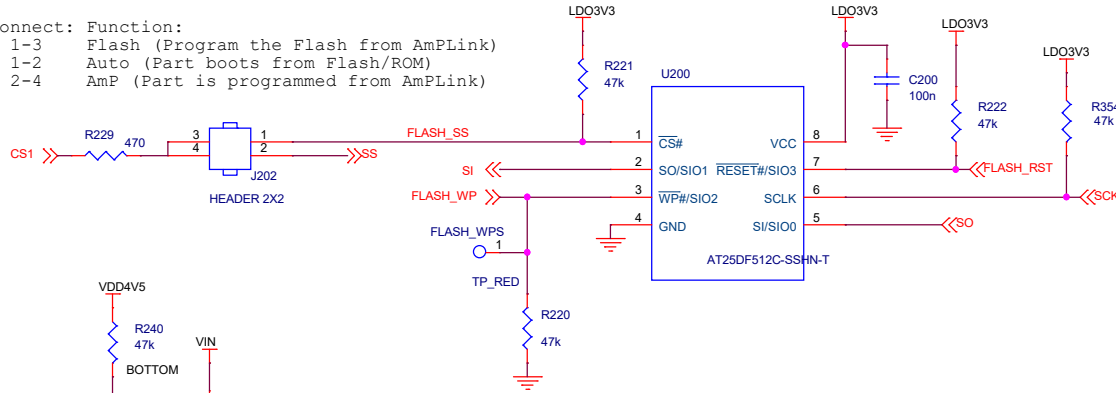

1-2 Sequencer input is "high"  
 2-3 Sequencer input is "low"  
 Floating: Sequencer input controlled by AmpLink/USB

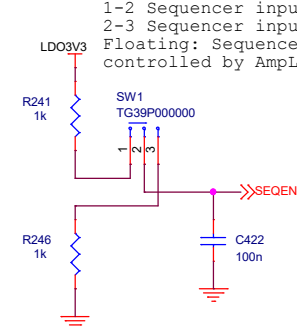

1-2 AUTO (Boots from internal/external ROM)  
 2-3 CLIENT (Boots from AmpLink/USB)  
 Floating: Not recommended

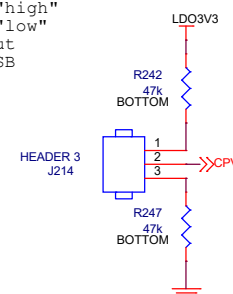

CPV02 is used as GPIO15MODE pin at startup.  
 This GPIO pin can only be configured as output and should be "soft" driven at startup.

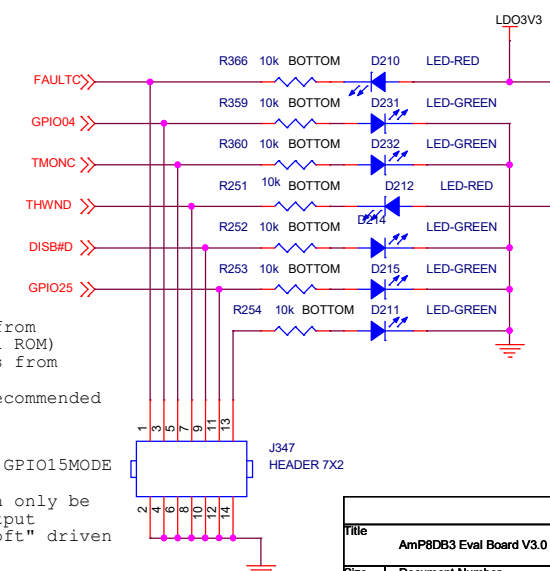

Title		
AmP8DB3 Eval Board V3.0		
Size	Document Number	Rev
B	AmP8DB3-V3.0.pdf	1.1
Date:	Wednesday, June 08, 2022	Sheet 2 of 5



All resistors 0603  
 All caps <47uF are X5R  
 Caps <4.7uF: 0603 and >25V  
 Caps 47uF: 0805 and >6.3V  
 Caps 22uF: 0805 and >25V  
 Caps 10uF: 0603 and >6.3V

## 2-phase DrMOS with option for 2LC ripple reduction

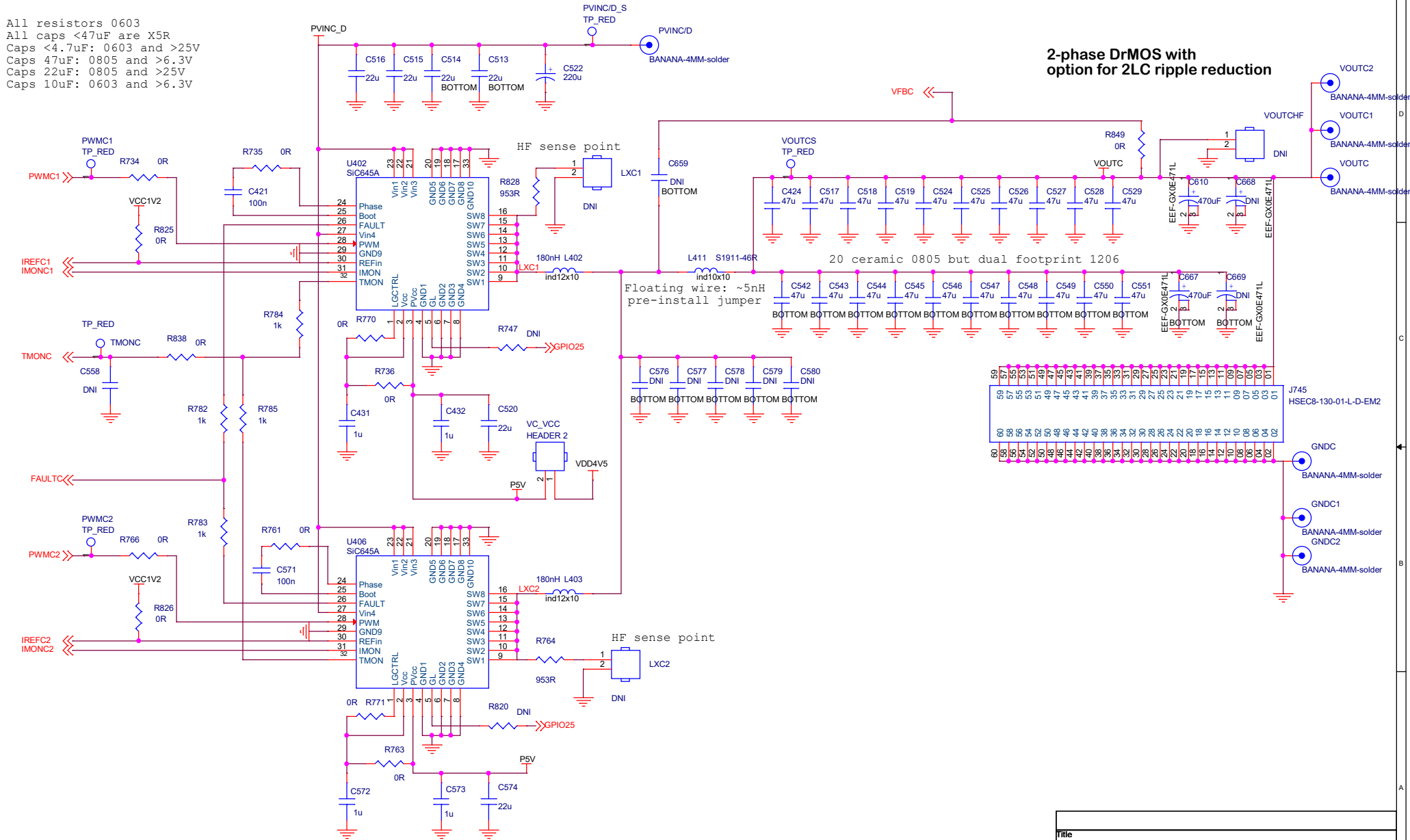

Title		
AmP8DB3 Eval Board V3.0		
Size	Document Number	Rev
B	AmP8DB3-V3.0.pdf	1.1
Date:	Wednesday, June 08, 2022	Sheet 3 of 5

All resistors 0603  
 All caps <47uF are X5R  
 Caps <4.7uF: 0603 and >25V  
 Caps 47uF: 0805 and >6.3V  
 Caps 22uF: 0805 and >25V  
 Caps 10uF: 0603 and >6.3V

THWND and DISB#D may need to be swapped for DrMOS of other vendors

**Supported parts:**  
 NCP302035  
 NCP302040  
 FDMF5820DC  
 AOZ5237QI  
 AOZ5339QI  
 AOZ5636QI

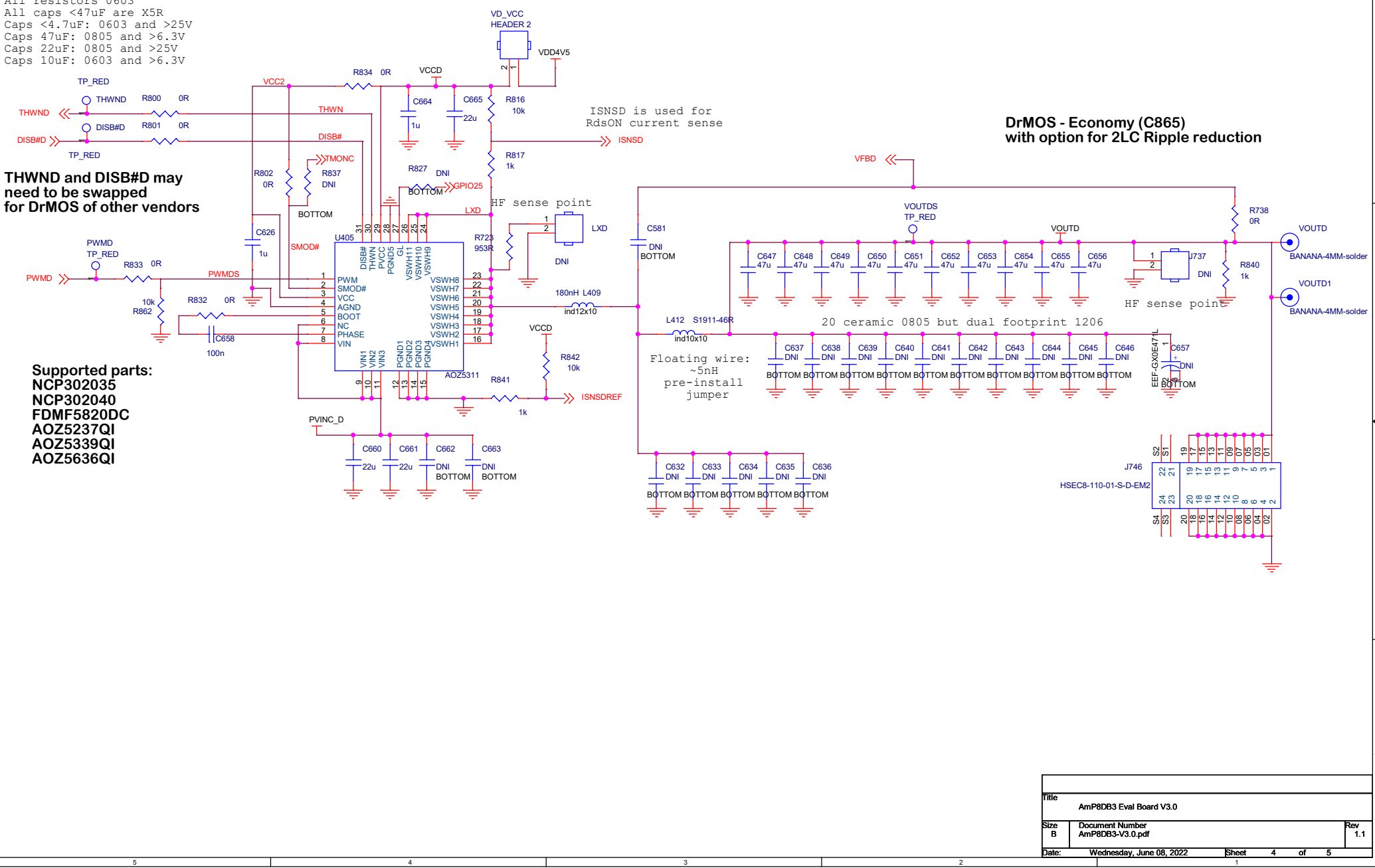

**DrMOS - Economy (C865)  
 with option for 2LC Ripple reduction**

Title		
AmpP8DB3 Eval Board V3.0		
Size	Document Number	Rev
B	AmpP8DB3-V3.0.pdf	1.1
Date:	Wednesday, June 08, 2022	Sheet 4 of 5

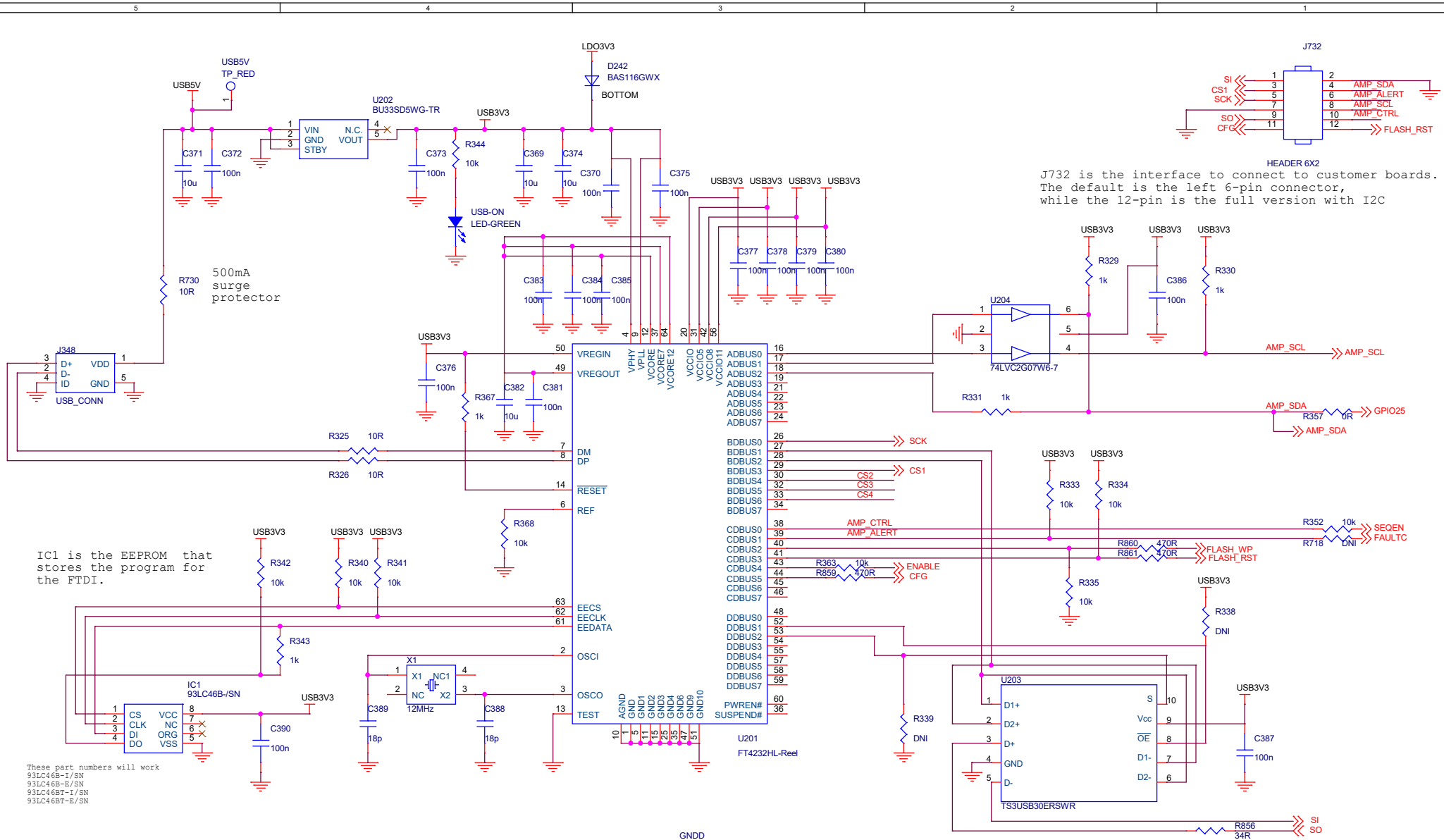

IC1 is the EEPROM that stores the program for the FTDI.

J732 is the interface to connect to customer boards. The default is the left 6-pin connector, while the 12-pin is the full version with I2C

These part numbers will work  
 93LC46B-1/SN  
 93LC46B-E/SN  
 93LC46BT-1/SN  
 93LC46BT-E/SN

All resistors 0603  
 All caps <47uF are X5R  
 Caps <4.7uF: 0603 and >25V  
 Caps 47uF: 0805 and >6.3V  
 Caps 22uF: 0805 and >25V  
 Caps 10uF: 0603 and >6.3V



Title		
Amp8DB3 Eval Board V3.0		
Size	Document Number	Rev
B	Amp8DB3-V3.0.pdf	1.1
Date:	Wednesday, June 08, 2022	Sheet 5 of 5

